

The ability to interface a position encoder to a Servo Drive can provide vital position information to the motion control system.

This approach is simple, yet effective, because information for the "encoder axis" is available to be used in the same way that information is used from any "servo axis".

### Remote Encoders Uses

- 1) **Pacer Encoders** measure real-time shaft position data of a machine axis. It is sent to other servo axes in the system for **electronic gearing** and/or **cam profiling** applications.
- 2) **Programmable limit switches** on each Servo Drive can be configured to turn on or off based on pacer encoder position.
- 3) **Position and velocity information** is accessible from the application program for every encoder used with SMLC and XD-Indexer systems.
- 4) **Remote Feedback Encoders** can be used to provide position feedback directly from the load under control, usually used in conjunction with velocity feedback from the servo motor shaft. It provides an additional level of precision in the control system.

### ServoWire Drive Interface

The encoder interface is a partial servo axis interface consisting only of differentially received quadrature A and B channels and a reference Z-channel. Selecting the "encoder input" axis control mode disables servo drive alarm detection but still provides open wire detection to insure encoder position information integrity.

### Optical Position Encoders

ORMEC Model EDR-25 optical, incremental position encoders are ideal for a wide variety of rugged industrial applications where reliability is a prime concern.

The EDR-25 provides a 1/4 cycle wide gated zero reference output. Models with cycle interpolation have maximum resolutions up to 200,000 counts per shaft revolution.

### Electrical Specifications

**Excitation voltages:** 5 VDC @ 100 mA maximum.

**Output format:** Two outputs (A and B) in phase quadrature with a zero reference (Z) output

**Output Specifications:** Output stage is an MC3487 (or performance equivalent) differential line driver with 20 ma sink and -20 ma source current.

### Mechanical Specifications

**Maximum Shaft loading (axial & radial):** 80 lb. max. Rated load of 20-40 lb.

**Shaft radial runout:** 0.001" max. at center of shaft length

**Maximum Starting torque at 25C:** 1.0 oz-in typical with IP64 shaft seal or no seal

3.0 oz-in typical with IP66 shaft seal

**Shaft angular acceleration:**

$10^5$  radians/sec<sup>2</sup> (maximum)

**Moment of inertia:**  $5.2 \times 10^{-4}$  oz-in-sec<sup>2</sup>

**Bearing type:** Precision ABEC ball bearing

**Minimum Bearing Life:**  $1.5 \times 10^9$  revolutions at rated shaft loading.



**Shaft:** 303 stainless steel

**Maximum shaft speed:** 8000 RPM or 200 KHz count channel output frequency, whichever occurs first (before cycle interpolation).

**Weight:** 11 oz. typical (25S)  
14 oz. typical (25C)

### Environmental Specifications

**Operating temperature range:** 0 to +70C

**Storage temperature range:** -25 to +85C

**Maximum Shock:** 75G's for 11 milliseconds duration

**Vibration:** 20G at 58 Hz to 500 Hz

**Maximum Humidity:** 98% R.H. (non-condensing)

### ORDERING GUIDE

### Lineshaft Pacer Encoders

EDR-25S/A1000	Position Encoder: 1000 linecount, provides 4,000 counts/rev
EDR-25S/A1250	Position Encoder: 1250 linecount, provides 5,000 counts/rev
EDR-25S/A2500	Position Encoder: 2500 linecount, provides 10,000 counts/rev
EDR-25S/A5000	Position Encoder: 5000 linecount, provides 20,000 counts/rev
EDR-25S/B5000	Position Encoder: 10,000 linecount, provides 40,000 counts/rev
EDR-25S/E2500	Position Encoder: 12,500 linecount, provides 50,000 counts/rev
EDR-25S/D5000	Position Encoder: 20,000 linecount, provides 80,000 counts/rev
EDR-25S/E5000	Position Encoder: 25,000 linecount, provides 100,000 counts/rev
EDR-25S/F5000	Position Encoder: 25,000 linecount, provides 100,000 counts/rev, high freq.
EDR-25S/G5000	Position Encoder: 50,000 linecount, provides 200,000 counts/rev, high freq.

Note: To specify encoder with flange mount and integral coupling, replace "25S" in model numbers above with "25C".

CBL-QE25SW/X	Encoder Cable, EDR-25 to ServoWire Drive, 5-150 ft
CBL-QE25SWV/X	Encoder Cable, EDR-25 to ServoWire Drive, IP-67, water-resistant, 5-150 ft
CBL-AXEQE15/X	Encoder Cable, EDR-25 to SAC-XD Drive, 5-150 ft
CBL-AXEQE15V/X	Encoder Cable, EDR-25 to SAC-XD Drive, IP-67, water-resistant, 5-150 ft
CON-E25	Encoder Connector kit for EDR-25 Encoders

## EDR-25S Outline Drawing

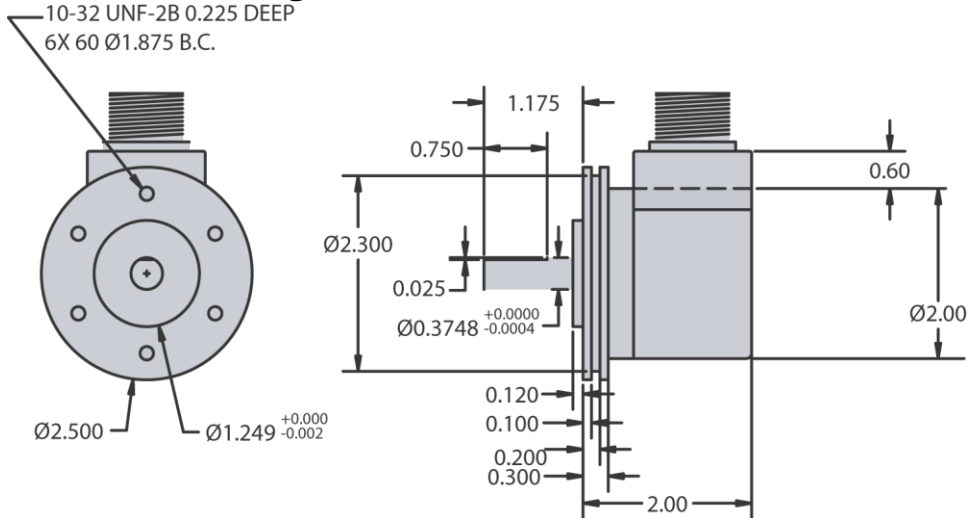

## EDR-25C Outline Drawing

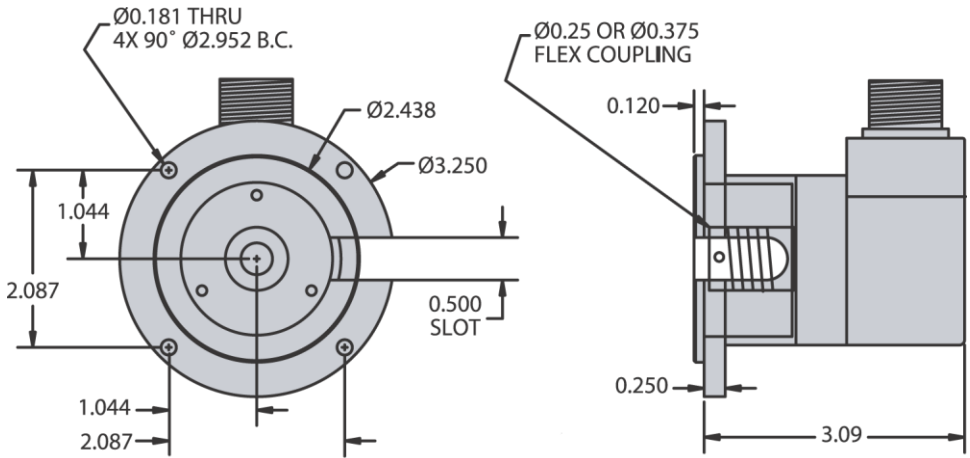

©2013 Technical information is subject to change without notice  
ServoWire and ORMEC are registered trademarks of ORMEC Systems Corp. All other trademarks are property of their respective owners.

ORMEC is an ISO 9001:2008 certified company committed to compliance with applicable laws and regulations, including the Restriction of Hazardous Substances Directive (RoHS).

**ORMEC Systems Corp.**  
19 Linden Park  
Rochester, NY 14625  
(585) 385-3520  
www.ormec.com  
Sales: sales@ormec.com

130716