

QuickPanel 2

Touchscreen Interfaces

Installation and Operation Manual
MMI-QP2b

Copyright (c) 1998

Ormec Systems Corp.

All rights reserved.

19 Linden Park

Rochester, NY 14625

(716) 385-3520

April 15, 1998

Copyright Notice

Copyright 1997, 1998 by Ormec Systems Corp. All rights reserved. This manual and the software it describes, remain the exclusive property of Ormec Systems Corporation. No part of either may be reproduced in any form without the prior written permission of Ormec.

Warranty

Ormec extends no warranty with respect to the merchantability or fitness for any particular purpose for this software. It is the customer's responsibility to determine whether it is suitable for the specific application and whether it meets performance, reliability, and safety requirements when used in that application.

Terms and Conditions of Sale

All software sold or otherwise provided by Ormec is made available subject to Ormec's published Standard Terms And Conditions Of Sale.

Trademarks

QuickDesigner and QuickPanel are trademarks of Total Control, Inc.

ORION and MotionDesk are trademarks of Ormec Systems Corp. MotionBASIC is a registered trademark of Ormec Systems Corp.

Table Of Contents

1 Welcome	page 1
2 General Description	page 3
2.1 QuickPanel Model Number Description	page 4
2.1.1 Cabinet Mounted Units	page 4
2.1.2 Hand Held Units	page 4
2.1.3 QuickPanel 2 Model Number List	page 5
2.2 Differences between QuickPanel (MMI-QP/___) and QuickPanel 2 (MMI-QP2/___) Units	page 5
3 Installation	page 7
3.1 Receiving & Inspection	page 7
3.2 QuickPanel 2 Installation	page 7
3.2.1 QuickPanel 2 Unit Identification	page 7
3.2.2 QuickPanel 2 Mounting Dimensions	page 8
3.2.3 QuickPanel 2 Enclosure Mounting	page 9
3.2.4 5" and 6" QuickPanel 2 Rear View and Power Wiring	page 11
3.2.4.1 9" EL QuickPanel 2 Rear View and Power Wiring	page 12
3.2.5 10.5" and 12.1" QuickPanel 2 Rear View and Power Wiring	page 15
3.2.6 Hand Held QuickPanel 2 Rear View and Cabling	page 17
3.2.6.1 Hand Held QuickPanel 2 CN1	page 19
3.2.7 Hand Held QuickPanel 2 Terminal Block Wiring	page 21
3.2.7.1 Input Power Terminal Strip, TB1	page 21
3.2.7.2 E-Stop Terminal Strip, TB2	page 21
3.2.7.3 Buzzer Terminal Strip, TB3	page 22
3.2.8 QuickPanel 2 Serial Communications	page 23
3.2.9 QuickPanel 2 TOOL Port	page 24
3.3 NEMA 4X Bezels	page 25
3.3.1 NEMA 4X Bezel Mounting	page 25
3.3.2 NEMA 4X Bezel Mounting Dimensions	page 27
3.4 Keypad Installation	page 30
3.4.1 Keypad Mounting	page 31
3.4.2 Keypad Beep Configuration	page 33
3.4.3 Changing the Keypad Function Key Labels	page 34
4 Operation, Maintenance & Troubleshooting	page 35
4.1 Powerup Operation	page 35
4.2 QuickPanel 2 Program Download	page 35
4.3 Upgrading the QuickPanel 2 Executive Software	page 36
4.4 Replacing the Cabinet Mounted QuickPanel 2 Backlight Lamp	page 37

4.5 Replacing the Cabinet Mounted QuickPanel 2 Touch Screen Overlay	page 38
4.6 Installing QuickPanel 2 Protective Cover Sheets	page 39
4.7 QuickPanel Error Messages & Troubleshooting	page 40
4.7.1 PLC COM. ERROR (02:FA, FB, FC, 51)	page 40
4.7.2 RECEIVE DATA ERROR (02:FD)	page 40
4.7.3 PLC NOT RESPONDING (02:FE)	page 41
4.7.4 PLC NOT CONNECTED (02:FF)	page 41
4.7.5 SYSTEM ERROR	page 42
4.7.6 UNSUPPORTED TAG IN SCREEN DATA	page 42
4.7.7 ILLEGAL ADDRESS IN SCREEN DATA	page 43
4.7.8 SCREEN MEMORY DATA IS CORRUPT	page 43
4.7.9 CLOCK SETUP ERROR	page 43
4.7.10 SCREEN TRANSFER ERROR	page 43
4.8 QuickPanel Display Troubleshooting	page 44
4.8.1 Not all Panel Objects are Displayed	page 44
5 Specifications	page 45
5.1 General Specifications	page 45
5.2 Mechanical and Environmental Specifications	page 45
5.3 Power Specifications	page 46
5.4 Unit Specifications	page 46
5.5 European Union Ratings	page 48
5.6 UL Approval	page 48
5.7 Chemical Resistance Chart	page 49
Appendix A - QuickPanel Accessories	A-1
CON-QPMOD8 - 25-Pin D-Sub to MOD8 Adapter	A-1
CBL-MOD8/NNN - Shielded 8-wire modular cable	A-2
CBL-QPPWR/NNN - 5" & 6" QuickPanel power cable	A-3
Recommended 9" and 10.5" 24 VDC QuickPanel power wiring	A-4
Recommended 6" Hand Held QuickPanel system wiring	A-5

Chapter 1

Welcome

1 Welcome

This manual describes installation and operation of ORMEC's QuickPanel 2 (MMI-QP2/___ and MMI-QP2H/6_U) family of Touchscreen Operator Interface Devices.

The manual is divided into the following chapters:

- | | |
|-----------|---|
| Chapter 1 | Welcome introduces you to this manual and its overall organization. |
| Chapter 2 | General Description provides an overview of the QuickPanel 2 family of products, including a list of all the products covered by this manual. This section also contains a brief description of the differences in operation between QuickPanel (MMI-QP/___) and QuickPanel 2 (MMI-QP2/___) units. |
| Chapter 3 | Installation explains how to install the unit and connect it to an ORION Motion Controller. |
| Chapter 4 | Operation & Maintenance explains the basic powerup and operation of the QuickPanel 2 products, as well as the maintenance of the unit. |
| Chapter 5 | Specifications covers general, electrical, mounting and environmental specifications for the QuickPanel 2 family. |
| Appendix | The Appendix contains detailed drawings for the QuickPanel 2 serial communications cable, connector adapter, and power wiring. |

Chapter 2

General Description

2 General Description

ORMEC QuickPanel 2 flatpanel touchscreen operator interfaces provide a cost-effective, intuitive, means of controlling an automated machine using servo control. Using a QuickPanel 2 is as intuitive as using a push-button control panel because the display provides the look of push-buttons and switches while the touch screen allows the natural act of touching them to initiate action.

During actual operation, a QuickPanel 2 interface is far easier to learn to use because it can be configured to present only the controls that make sense for use at a particular point in the machine operation. The QuickPanel 2 interface, in conjunction with ORMEC's ORION™ Motion Controllers and a well written application program, also provides an excellent means of operator diagnostics and troubleshooting when a problem occurs with the automation.

The family of QuickPanel 2 Products covers a substantial range of price and performance, with display panels ranging from 5" Monochrome to 10.5" Color TFT, cabinet mounted and hand held units, which all share the common QuickDesigner 2 development environment. This unified development environment provides the benefit of being a single software investment, with a short learning curve, which is highly integrated with ORION's motion control software and its development environment.

2.1 QuickPanel Model Number Description

2.1.1 Cabinet Mounted Units

MMI-QP2/SCO₁O₂

	<u>Screen Size (required)</u>
S	= 5 (5.0" diagonal screen, 320x240 pixels)
	= 6 (6.0" diagonal screen, 320x240 pixels)
	= 9 (9.0" diagonal screen, 640x400 pixels)
	= 10 (10.5" diagonal screen, 640x480 pixels)
	= 12 (12.1" diagonal screen, 640x480 pixels) ¹
	<u>Display Type (required)</u>
C	= M (monochrome LCD)
	= E (electroluminescent monochrome)
	= C (Dual Scan STN color)
	= T (TFT color)
	<u>UL or CE Mark (not required for 9" and 10.5" QuickPanels)</u>
O ₁	= blank (120 VAC input, neither UL Listed or CE Marked)
	= U (24 VDC input, UL Listed units)
	= E (24 VDC input, CE Marked units)
	<u>NEMA 4X Enclosure (not required)</u>
O ₂	= 4X (unit includes stainless steel NEMA 4X bezel)

2.1.2 Hand Held Units

MMI-QP2H/6CU¹

	<u>Display Type (required)</u>
C	= M (monochrome LCD)
	= C (Dual Scan STN color)

¹ 12.1" TFT and 6" Hand Held QuickPanels require MBX-QP version 1.2a (or later) for MB 3.x or MBX-QP-4 version 2.2.0 (or later) for MB 4.x.

2.1.3 QuickPanel 2 Model Number List

Cabinet Mounted Units	
Model	Description
MMI-QP2/5MU	5" Mono LCD, 24 VDC input power, UL Listed
MMI-QP2/5ME	5" Mono LCD, 24 VDC input power, CE
MMI-QP2/5CU	5" STN Color LCD, 24 VDC input power, UL Listed
MMI-QP2/5CE	5" STN Color LCD, 24 VDC input power, CE
MMI-QP2/6MU	6" Mono LCD, 24 VDC input power, UL Listed
MMI-QP2/6ME	6" Mono LCD, 24 VDC input power, CE
MMI-QP2/6CU	6" STN Color LCD, 24 VDC input power, UL Listed
MMI-QP2/6CE	6" STN Color LCD, 24 VDC input power, CE
MMI-QP2/9E	9" Mono EL, 120 VAC input power
MMI-QP2/9EU	9" Mono EL, 24 VDC input power, UL Listed
MMI-QP2/9EE	9" Mono EL, 24 VDC input power, CE
MMI-QP2/10MU	10.5" Mono LCD, 24 VDC input power, UL Listed
MMI-QP2/10ME	10.5" Mono LCD, 24 VDC input power, CE
MMI-QP2/10C	10.5" STN Color LCD, 120 VAC input power
MMI-QP2/10CU	10.5" STN Color LCD, 24 VDC input power, UL Listed
MMI-QP2/10CE	10.5" STN Color LCD, 24 VDC input power, CE
MMI-QP2/10T	10.5" TFT Color, 120 VAC input power
MMI-QP2/10TU	10.5" TFT Color, 24 VDC input power, UL Listed
MMI-QP2/10TE	10.5" TFT Color, 24 VDC input power, CE Listed
MMI-QP2/12T	12" TFT Color, 120 VAC input power
Hand Held Units	
Model	Description
MMI-QP2H/6MU	Hand Held 6" Mono LCD, 24 VDC input power
MMI-QP2H/6CU	Hand Held 6" STN Color, 24 VDC input power

Table 1, Complete list of all valid QuickPanel 2 Model Numbers

2.2 Differences between QuickPanel (MMI-QP/___) and QuickPanel 2 (MMI-QP2/___) Units

New Features

- *Floating Point and 32-Bit Integer Support* - QuickPanel 2 units (MMI-QP2/___) support floating point and 32 bit integers. Refer to the QuickManager Help Tags section for further information.
- *Additional Panel Objects* - The QuickPanel 2 (MMI-QP2/___) offers a trending display, 180° and 360° analog meters, local image display for creating dynamic graphics, panel drawing tools (line, circle, text, etc.), and a print screen pushbutton. Refer to the QuickManager Help for further information.
- *Increased Program Memory* - The QuickPanel 2 (MMI-QP2/___) units have approximately 3 times the program memory as the QuickPanel units

(MMI-QP/___). Refer to the Unit Specifications section of the Specification chapter for further program memory information.

- *Reduced Display Update Time* - The QuickPanel 2 (MMI-QP2___) units utilize a RISC microprocessor and graphics chip to provide significantly faster screen updates than those of the QuickPanel units (MMI-QP/___).

Differences between MMI-QP2 and MMI-QP units

- *QuickPanel 2 requires MBX-QP ver. 1.2a (or later) for MB 3.x or MBX-QP-4 ver. 2.1.0 (or later) for MB 4.x.* 12.1" TFT and 6" Hand Held QuickPanels require MBX-QP version 1.2a (or later) for MB 3.x or MBX-QP-4 version 2.2.0 (or later) for MB 4.x. Earlier versions of the QuickPanel MotionBASIC Extension will not properly download an application program into a QuickPanel 2 unit, however, the serial communications will function normally.
- *QuickPanel 2 always saves the application program to Flash memory* - The QuickPanel 2 utilizes an improved (faster) Flash memory burn algorithm, which saves the application program as it is downloaded. **Do not abort a download once it has begun, otherwise you will need to use the QuickPanel Direct Download utility to re-download the application program.**
- *The Serial Communications Port Settings in QuickDesigner 2 affect the QuickPanel 2* - The serial communications port settings in QuickDesigner (MDK-QDK/3) did not affect the serial communications of the QuickPanel (MMI-QP/___). This is not true for the QuickPanel 2 (MMI-QP2/___), which must have the correct serial communications port settings (baud rate 19,200, 8 data bits, 1 stop bit, no parity, no handshaking) in QuickDesigner 2 (MDK-QD2/3) for proper operation. If you download the wrong serial communications port setting, you will need to correct them and download the application program using the QuickPanel Direct Download utility.
- *The ~System_Comm_Status and ~System_Contrast internal tags are not supported* - Because the QuickPanel 2 displays communications error message automatically, support for the ~System_Comm_Status variable has been dropped. QuickPanel 2 units have a built-in contrast adjustment function which is accessible by simultaneously pressing top two corners of the touchscreen.
- The QuickPanel 2 writes a value greater than 4000 to the Panel Trigger Tag whenever the numeric data entry keypad is displayed. You must modify your MotionBASIC program if it is using the Panel Trigger tag for decision making to take this into account, and your QuickDesigner 2 project cannot use a Panel ID greater than 3999.

Chapter 3

Installation

3 Installation

3.1 Receiving & Inspection

ORMEC's QuickPanel 2 Touchscreen Interfaces and Keypads are factory tested and carefully packaged for shipment. After unpacking, however, check for damage which may have been sustained in shipment and report any damage to your shipping company.

NOTE: The QuickPanel 2 and Keypad mounting hardware is packed inside the shipping carton. Remove the QuickPanel 2 and Keypad mounting hardware, cabling, and all other parts from the shipping carton prior to discarding it.

3.2 QuickPanel 2 Installation

3.2.1 QuickPanel 2 Unit Identification

The product label on the back of the unit contains the model number and serial number. You should identify the model number and its corresponding display type from the list below because you will need to be able to identify the display type when you use the QuickDesigner 2 software.

Cabinet Mounted QuickPanel 2 Units	
Model Number	Display Type in QuickDesigner 2
MMI-QP2/5M_	QUICKPANEL jr. 5" (QPJ) LCD Monochrome
MMI-QP2/5C_	QUICKPANEL jr. 5" (QPJ) Color
MMI-QP2/6M_	QUICKPANEL jr. 6" (QPK) LCD Monochrome
MMI-QP2/6C_	QUICKPANEL jr. 6" (QPK) Color
MMI-QP2/9E_	QUICKPANEL 9" EL Monochrome
MMI-QP2/10MU	QUICKPANEL 10.5" LCD Monochrome
MMI-QP2/10C_	QUICKPANEL 10.5" Color
MMI-QP2/10T_	QUICKPANEL 10.5" Color
MMI-QP2/12T	QUICKPANEL 12.1" Color TFT
Hand Held QuickPanel 2 Units	
MMI-QP2H/6MU	QUICKPANEL 6" Hand Held Monochrome
MMI-QP2H/6CU	QUICKPANEL 6" Hand Held Color

Table 2, QuickDesigner 2 Display Type Cross Reference

3.2.2 QuickPanel 2 Mounting Dimensions

Figure 1 and Table 1 indicate QuickPanel 2 Touchscreen Mounting Dimensions.

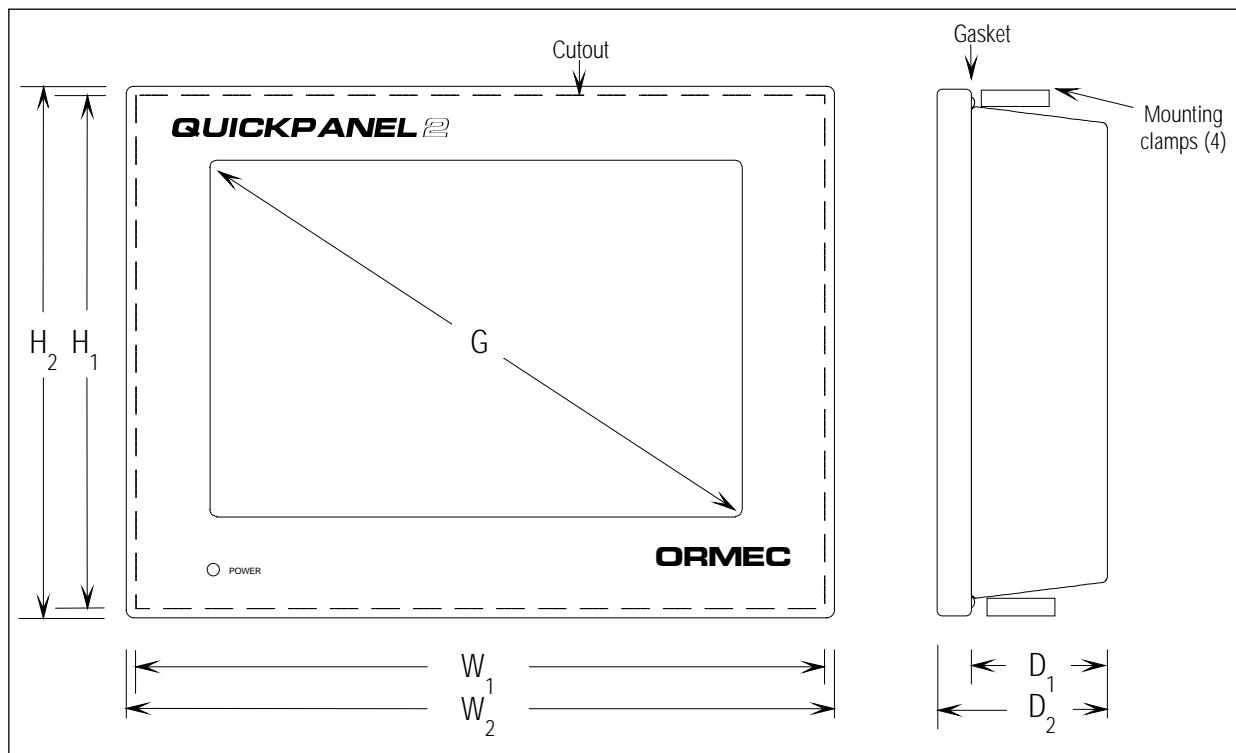

Figure 1, QuickPanel 2 Dimension Drawing

Model No.	----- Mounting Cutout -----				----- Overall Dimensions -----		
	G	H ₁	W ₁	D ₁	H ₂	W ₂	D ₂
MMI-QP2/5M_	5" 127 mm	4.45 113 mm	6.20" 158 mm	2.1" 54 mm	5.0" 127 mm	6.8" 172 mm	2.3" 59 mm
MMI-QP2/5C_	5" 127 mm	4.45 113 mm	6.20" 158 mm	2.1" 54 mm	5.0" 127 mm	6.8" 172 mm	2.3" 59 mm
MMI-QP2/6M_	6" 152 mm	4.9" 123 mm	6.10" 155 mm	2.3" 57 mm	4.8" 120 mm	6.7" 171 mm	2.4" 62 mm
MMI-QP2/6C_	6" 152 mm	4.9" 123 mm	6.10" 155 mm	2.3" 57 mm	5.4" 138 mm	6.7" 171 mm	2.4" 62 mm
MMI-QP2/9E_	9" 230 mm	7.91" 200 mm	10.20" 258 mm	1.9" 49 mm	8.5" 216 mm	10.8" 274 mm	2.0" 57 mm
MMI-QP2/10C_	10.5" 267 mm	8.97" 228 mm	11.88" 302 mm	3.1" 78 mm	9.6" 243 mm	12.5" 317 mm	3.4" 85 mm
MMI-QP2/10T_	10.5" 267 mm	8.97" 228 mm	11.88" 302 mm	3.1" 78 mm	9.6" 243 mm	12.5" 317 mm	3.4" 85 mm
MMI-QP2/12T	12.1" 307 mm	10.16" 258 mm	13.07" 332 mm	2.9" 73.5 mm	10.7" 272 mm	13.62" 346 mm	3.2" 81 mm

Table 3, QuickPanel 2 Mounting Dimensions

3.2.3 QuickPanel 2 Enclosure Mounting

QuickPanel 2 units mount from the front and are secured to the panel with two pressure clamps each on the top and bottom of the display as shown in Figure 2.

- In order to provide adequate operator accessibility, and sufficient ventilation, it is recommended that QuickPanels be mounted with at least 4" (102 mm) clearance around the unit.
- Ensure that the QuickPanel 2 is located as far away as possible from electromagnetic circuits, circuit breakers, and other equipment which causes arcing.
- The mounting enclosure panel thickness should be between 0.062" (1.6 mm) and 0.3937" (10 mm).
- QuickPanel units must be mounted vertically to allow convection cooling. Ensure that heat from other equipment is not adding heat to the QuickPanel. Forced air cooling is required if the unit is to be using in an ambient temperature greater than 50C.
- Route all serial communications cabling in a separate wireway from the power wiring. Use shielded cable for power wiring, and connect the shield to the Frame Ground terminal on the input power terminal strip.
- Do not hit the touch screen with a hard or heavy object, or press the touch screen with excessive force.
- Do not use paint thinner or organic solvents to clean QuickPanels.

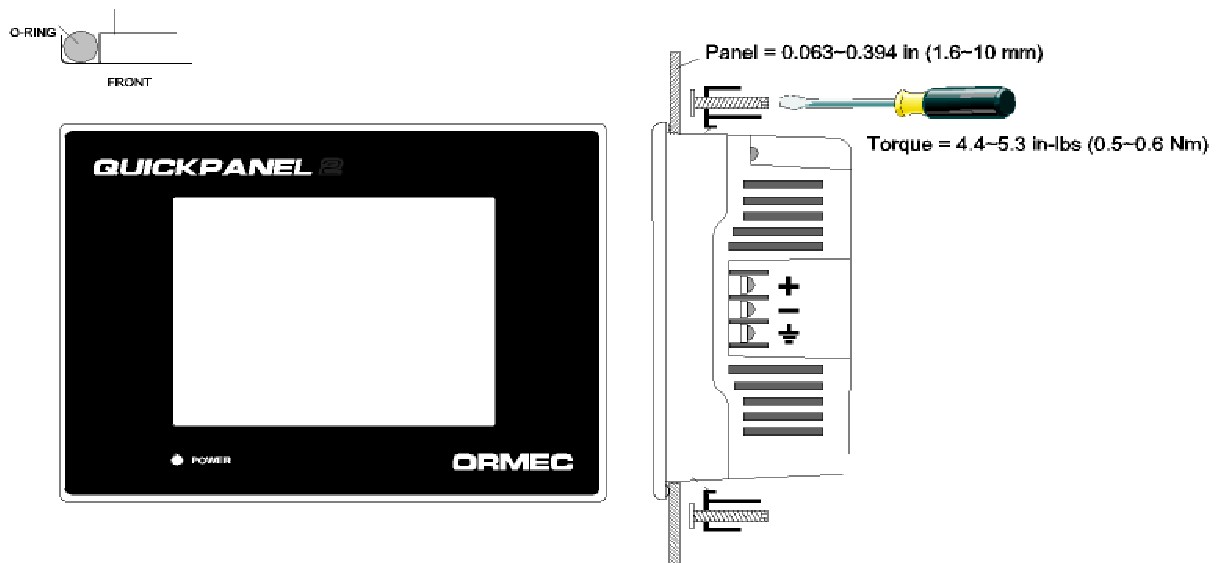

Figure 2, QuickPanel 2 Panel Installation Drawing

To mount a QuickPanel 2 unit in an enclosure panel:

- 1) Make the panel cutout as shown in the Figure 1 and Table 2.
- 2) Install the O-ring gasket in the slot around the edge of the display, as shown in Figure 2.
- 3) Insert the display into the cutout and install two clamp brackets each on the top and bottom of the display (4 clamps total), as shown in Figure 2. The Clamp brackets are installed by inserting the hooked section into the clamp slot and sliding the clamp bracket down.
- 4) Compress the O-ring gasket and secure the unit to the panel by turning the clamp screws clockwise, as shown in Figure 2. The screw torque required for a water tight gasket seal is 4.4 to 5.3 in-lbs (0.5 to 0.6 NM).

3.2.4 5" and 6" QuickPanel 2 Rear View and Power Wiring

Figure 3 shows a rear view of the 5" and 6" QuickPanel 2 units.

- The input power terminal strip provides power and ground connections to the unit, and you should observe the polarity for the +24 VDC connections.
- The serial interface port (SIO) connects the QuickPanel 2 to your ORION motion controller. The connector shown is permanently installed with 2.5 mm metric machine screws. Cabling is attached by inserting an 8-pin modular plug (RJ45) into the right end of the SIO connector.
- The TOOL port is provided to download new executive software into the unit, for connection of a QuickPanel 2 external keypad, or for connection of a Laser Printer. Your QuickPanel 2 operator interface screens are downloaded through the SIO connector.

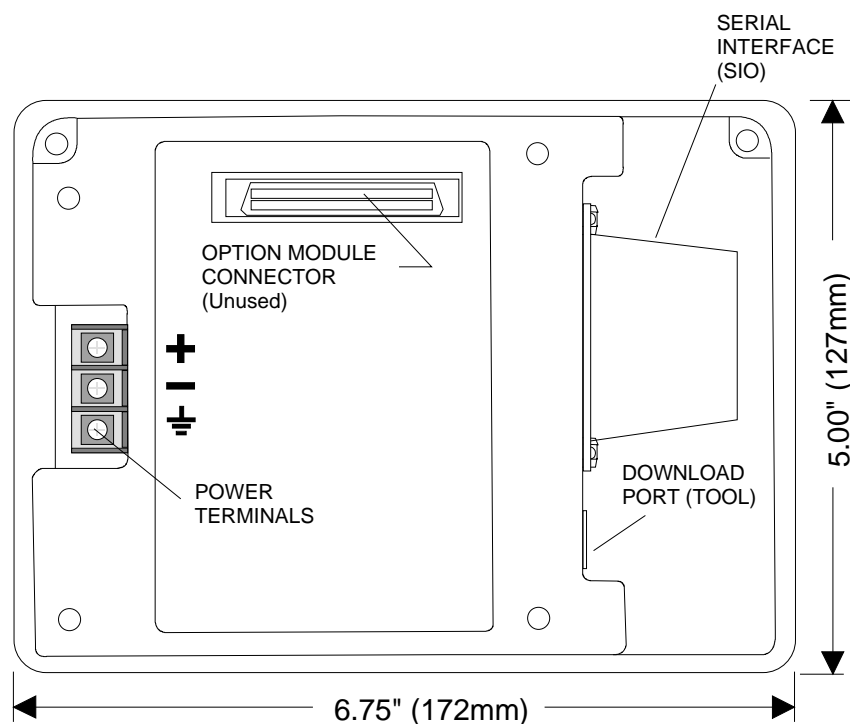

Figure 3, 5" and 6" QuickPanel 2 Rear View Outline Drawing

All 5" and 6" QuickPanel 2 units require 24 VDC input power. Refer to Figure 3, and to the Specifications chapter for the 5" and 6" QuickPanel 2 +24 VDC power requirements.

To connect power to the QuickPanel:

- 1) Lift the protective cover on the 24 VDC terminal strip.

- 2) Remove approximately 1/4 inch (6 mm) of insulation from the supply wires and insert them under the non-rotating self-rising terminal clamp.
- 3) Tighten the terminal clamp screws to secure the wires.
- 4) Add a frame ground wire to the terminal marked FG.
- 5) Replace the protective cover.

3.2.4.1 9" EL QuickPanel 2 Rear View and Power Wiring

Figure 4 shows a rear view of the 9" EL QuickPanel 2.

- The input power terminal strip provides power and ground connections to the unit, and you should observe the polarity for the 120 VAC and +24 VDC connections.
- The serial interface port (SIO) connects the QuickPanel 2 to your ORION motion controller. The connector shown is permanently installed with 2.5 mm metric machine screws. Cabling is attached by inserting an 8-pin modular plug into the right end of the SIO connector.
- The TOOL port is provided to download new executive software into the unit, or for connection of a Laser Printer. Your QuickPanel 2 operator interface screens are downloaded through the SIO connector.
- The AUX and PRINTER connectors are unused.

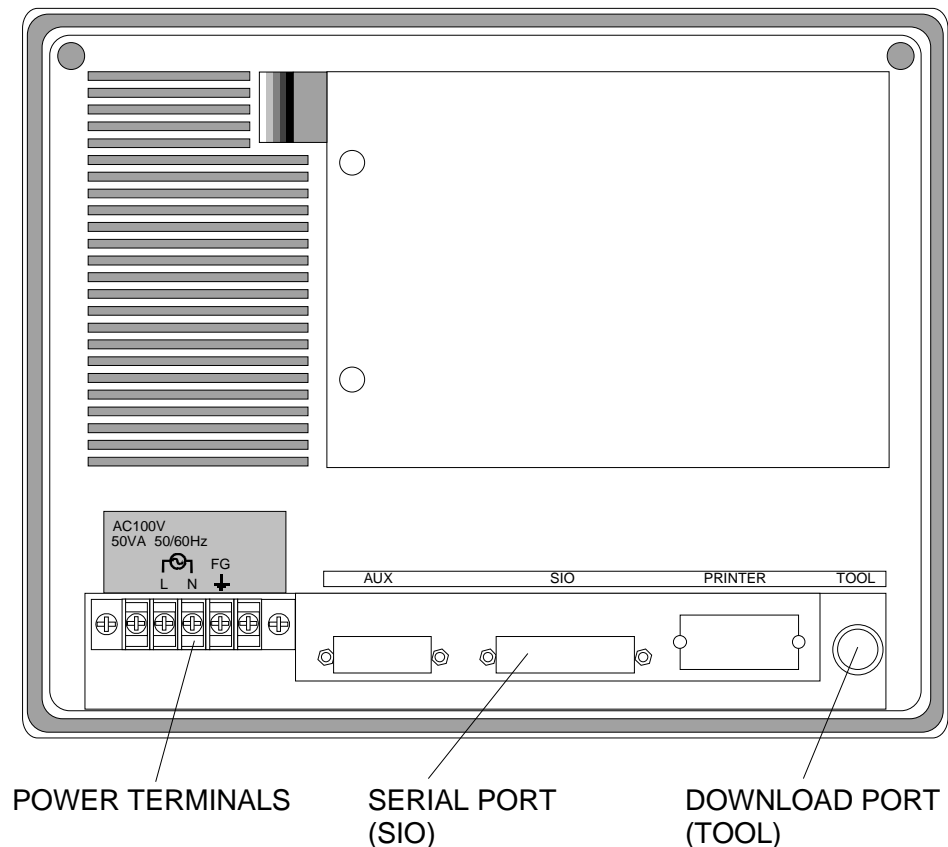

Figure 4. 9" EL QuickPanel 2 Rear View Outline Drawing

9" EL QuickPanel 2 units can operate on either 115 VAC or 24 VDC input power depending on the model. Refer to the QuickPanel Model Number Description section of the General Description chapter to determine the input power requirements for your model QuickPanel. Refer to Figures 4 and 5, and to the Specifications chapter for the 9" EL QuickPanel 2 +24 VDC or 120 VAC power requirements.

To connect power to the QuickPanel:

- 1) Remove the protective cover on the input power terminal strip.
- 2) Remove approximately 1/4 inch (6 mm) of insulation from the supply wires and insert them under the non-rotating self-rising terminal clamp.
- 3) Tighten the terminal clamp screws to secure the wires.
- 4) Add a frame ground wire to the terminal marked FG.
- 5) Replace the protective cover on the input power terminal strip.

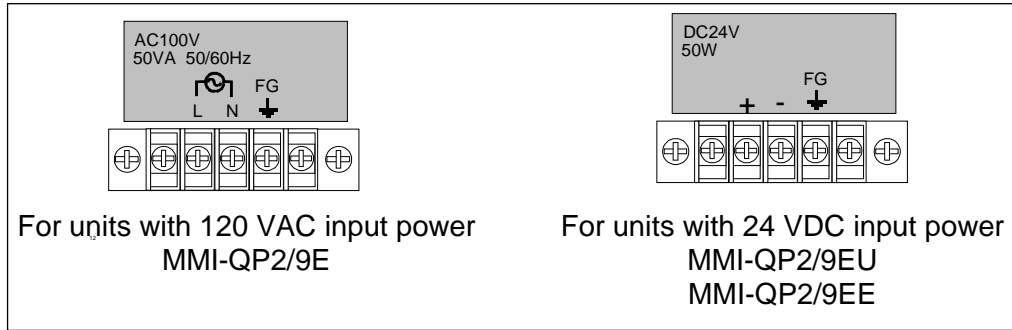

Figure 5, 9" EL QuickPanel 2 Input Power Terminal Strip Diagrams

3.2.5 10.5" and 12.1" QuickPanel 2 Rear View and Power Wiring

Figure 6 shows a rear view of the 10.5" and 12.1" QuickPanel 2 units.

- The input power terminal strip provides power and ground connections to the unit, and you should observe the polarity for the 120 VAC and +24 VDC connections.
- The serial interface port (SIO) connects the QuickPanel 2 to your ORION motion controller. The connector shown is permanently installed with 2.5 mm metric machine screws. Cabling is attached by inserting an 8-pin modular plug into the right end of the SIO connector.
- The TOOL port is provided to download new executive software into the unit, or for connection of a Laser Printer. Your QuickPanel 2 operator interface screens are downloaded through the SIO connector.
- The AUX and PRINTER connectors are unused.

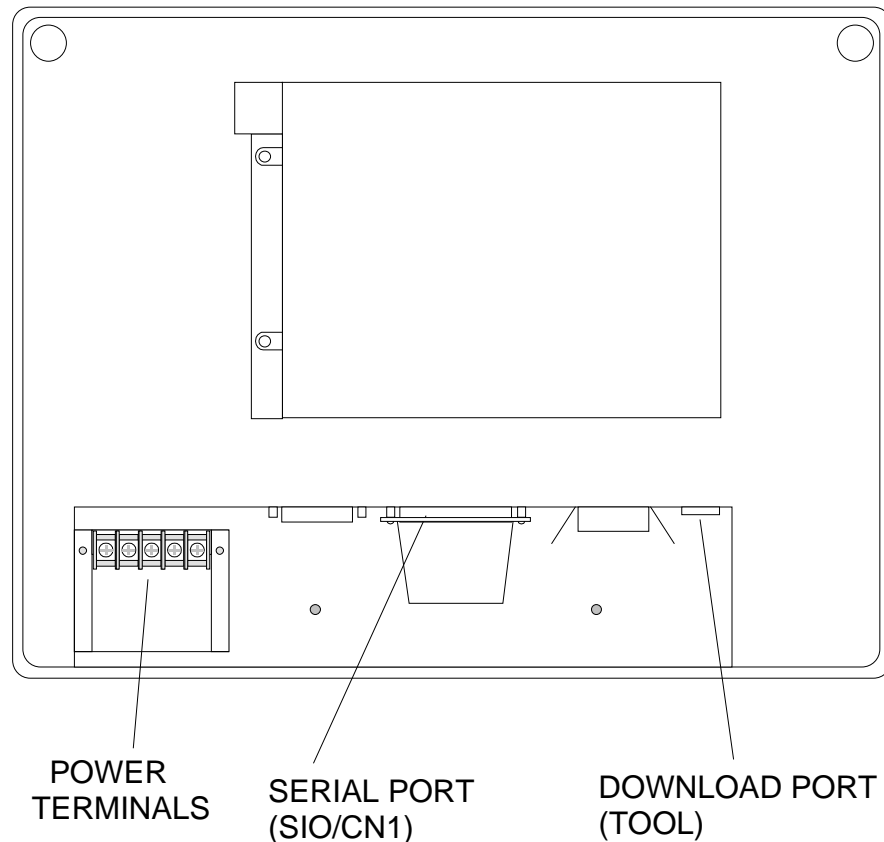

Figure 6, 10.5" and 12.1" QuickPanel 2 Rear View Outline Drawing

10.5" QuickPanel 2 units can operate on either 115 VAC or 24 VDC input power depending on the model. 12.1" QuickPanel 2 units operate on 115 VAC input power only. Refer to the QuickPanel Model Number Description section of the General Description chapter to determine the input power requirements for your

model QuickPanel. Refer to Figures 6 and 7, and to the Specifications chapter for the 10.5" and 12.1" QuickPanel 2 input power requirements.

To connect power to the QuickPanel:

- 1) Remove the protective cover on the input power terminal strip.
- 2) Remove approximately 1/4 inch (6 mm) of insulation from the supply wires and insert them under the non-rotating self-rising terminal clamp.
- 3) Tighten the terminal clamp screws to secure the wires.
- 4) Add a frame ground wire to the terminal marked FG.
- 5) Replace the protective cover on the input power terminal strip.

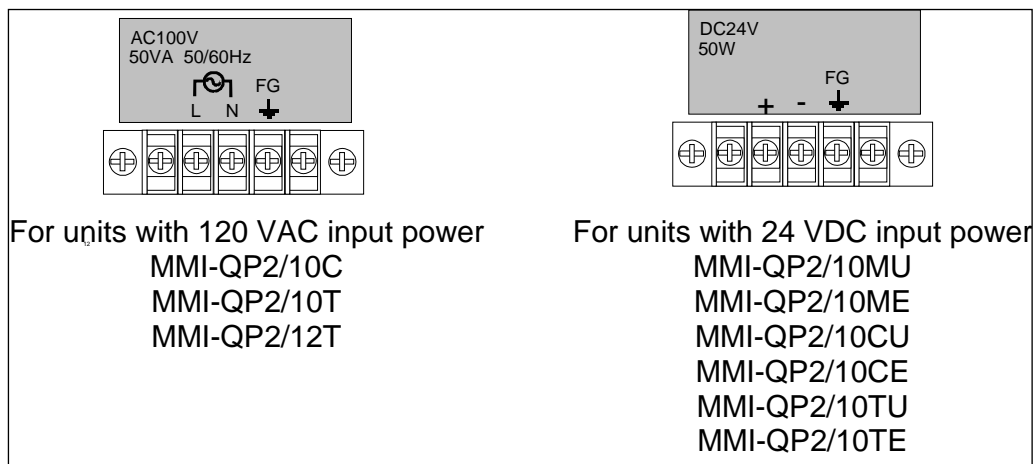

Figure 7, 10.5" & 12.1" QuickPanel 2 Input Power Terminal Strip Diagrams

3.2.6 Hand Held QuickPanel 2 Rear View and Cabling

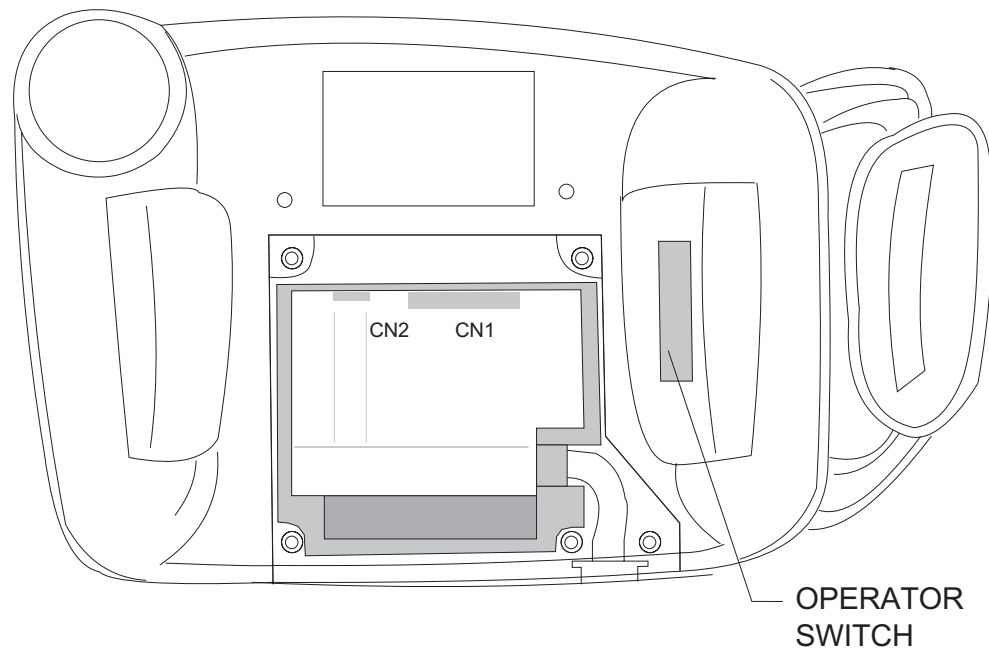

Figure 8, 6" Hand Held QuickPanel 2 Rear View Outline Drawing

- Input power, serial communications, and access to the E-Stop, buzzer, and operation contacts is provided through the Hand Held QP2 to Terminal Block cable (CBL-QP2H-TB/12 - supplied separately) connected to CN1. Refer to Appendix A-5 for a Hand Held QuickPanel system wiring diagram.
- The TOOL port (CN2) is provided to download new executive software into the unit, or for connection of a Laser Printer. Your QuickPanel 2 operator interface screens are downloaded through the cable connected to CN1.

To connect the Hand Held QP2 to Terminal Block cable (CBL-QP2H-TB/12):

- 1) Remove the back cover.
- 2) Connect the CBL-QP2H-TB/12 to CN1 such that the cord-grip strain relief provided on the cable can be inserted into the slot provided in the Hand Held QP2 housing (Refer to Figure 8).
- 3) Press the CBL-QP2H-TB/12 into the cable trough provided in the Hand Held QP2 housing (Refer to Figure 8). Be sure to place the neoprene gasket piece over the top of the cable after it is pressed into the cable trough.
- 4) Insert the cord-grip strain relief on the CBL-QP2H-TB/12 into the slot provided in the Hand Held QP2 housing (Refer to Figure 8). Be sure that the curved side of the cord grip strain relief is facing up, otherwise the back cover will not fit properly.
- 5) Replace the back cover.

3.2.6.1 Hand Held QuickPanel 2 CN1

The following is a description of connector CN1 on the Hand Held QuickPanel 2. The access to these connections is provided by CBL-QP2H-TB/12 and TBC-QP2H. Refer to Figure 9 for a drawing of the 6" Hand Held QuickPanel 2 CN1 connector, and Table 3 for a description of the pinout.

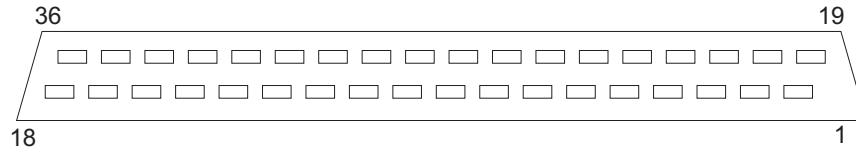

Figure 9, 6" Hand Held QuickPanel 2, Connector CN1

Pin #	Signal Name	Description
Case	FG	Frame Ground
1	RS	Request To Send (RS-232C)
2	CS	Clear To Send (RS-232C)
3	CD	Carrier Detect (RS-232C)
4	VCC	5 VDC output, 0.1A max.
5	TRMX	Termination (RS-422)
6	RxD	Receive Data + (RS-422)
7	TxD	Transmit Data + (RS-422)
8	CTS	Clear To Send + (RS-422)
9	RTS	Request To Send + (RS-422)
10	DOOUT1C	Unused
11	DOOUT0C	Unused
12	OP C	Collector of optically isolated Operation Pushbutton output
13	BUZZ OUT	Collector of optically isolated buzzer output
14	EMG A	Emergency Stop Pushbutton contact
15	NC	No Connection
16	+24V	Input +24 VDC Power (All three pins should be connected to power)
17	+24V	
18	+24V	
19	SD	Transmit Data (RS-232C)
20	RD	Receive Data (RS-232C)
21	ER	Enable to Receive (RS-232C)
22	SG	Signal Ground
23	NC	Not Connected
24	RxD'	Receive Data - (RS-422)
25	TxD'	Transmit Data - (RS-422)
26	CTS'	Clear To Send - (RS-422)
27	RTS'	Request To Send - (RS-422)
28	DOOUT1GND	Unused
29	DOOUT0GND	Unused
30	OP GND	Emitter of optically isolated Operation Pushbutton output
31	BUZZ GND	Emitter of optically isolated buzzer output
32	EMG B	Emergency Stop Pushbutton contact
33	NC	No Connection
34	0V	Input 24 VDC Power Common (All three pins should be connected to common)
35	0V	
36	0V	

Table 4, 6" Hand Held QuickPanel 2, Connector CN1 Description

3.2.7 Hand Held QuickPanel 2 Terminal Block Wiring

Figure 10 shows the Hand Held QP2 Terminal Block, Appendix A-5 shows the complete Hand Held QP2 system wiring.

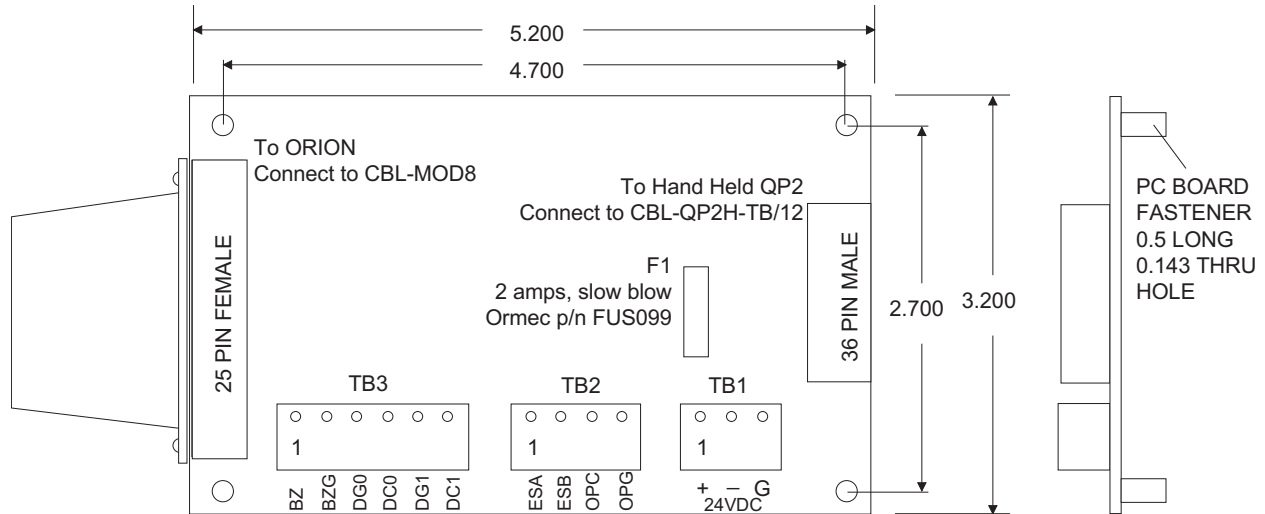

Figure 10, Hand Held QP2 Terminal Block, TBC-QP2H

3.2.7.1 Input Power Terminal Strip, TB1

The Input Power Terminal Strip (TB1) provides input power and ground connections to the Hand Held QP2, and you should observe the polarity indicated for the +24 VDC connections.

Terminal	Function	Description
+	Power Supply Common	Connections for +24 VDC power supply. Refer to the specifications section for further information regarding input power requirements for the Hand Held QP2.
-		
G	Ground	Ground connection.

3.2.7.2 E-Stop Terminal Strip, TB2

The E-Stop Terminal Strip (TB2) provides connections to the Hand Held QuickPanel 2 E-Stop switch contact and optically isolated Operation pushbutton output. Refer to Figure 11 for an electrical schematic of the E-Stop Terminal Strip connections.

WARNING: The Operation pushbutton contact is always enabled, regardless of the configuration of the Operation Switch Off checkbox in the QuickManager Setup Touch dialog box.

NOTE: The fuse indicated in the operation pushbutton output circuit is a fusible trace within the Hand Held QuickPanel, and is not field serviceable. If you think that this fusible trace is blown, please contact the ORMEC Service Department for assistance.

Terminal	Function	Description
ESA ESB	E-Stop Switch	Connections to the normally closed E-Stop switch contact. The E-Stop switch contact is rated for 30 VDC, 0.3A maximum.
OPC OPG	Operation PB Collector Operation PB Emitter	Connections to the optically isolated operation pushbutton output. This fused output is rated for 5 - 24 VDC, 0.1 - 0.3 amps.

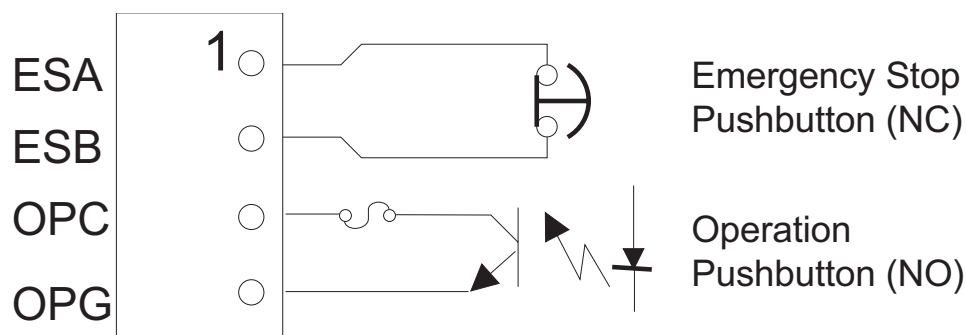

Figure 11, Hand Held QuickPanel 2 E-Stop Terminal Strip Schematic

3.2.7.3 Buzzer Terminal Strip, TB3

The Hand Held QP2 buzzer output can be used to connect the QP2 screen buzzer to an external beeper or other audio device. The buzzer output is enabled/disabled along with the screen buzzer, which is configured through the Touch Screen dialog box in QuickDesigner. This optically isolated output is normally off, and is asserted whenever the screen beeper sounds.

The Buzzer Terminal Strip (TB3) provides connections to the Hand Held QP2 optically isolated screen buzzer output. Refer to Figure 12 for an electrical schematic of the Buzzer Terminal Strip connections.

NOTE: The fuse indicated in the buzzer output circuit is a fusible trace within the Hand Held QuickPanel, and is not field serviceable. If you think that this fusible trace is blown, please contact the ORMEC Service Department for assistance.

Terminal	Function	Description
BZ BZG	Buzzer Collector Buzzer Emitter	Connections to the optically isolated screen buzzer output. This fused output is rated for 5 - 24 VDC, 0.1 - 0.3 amps.
DG0 DC0	Unused	
DG1 DC1	Unused	

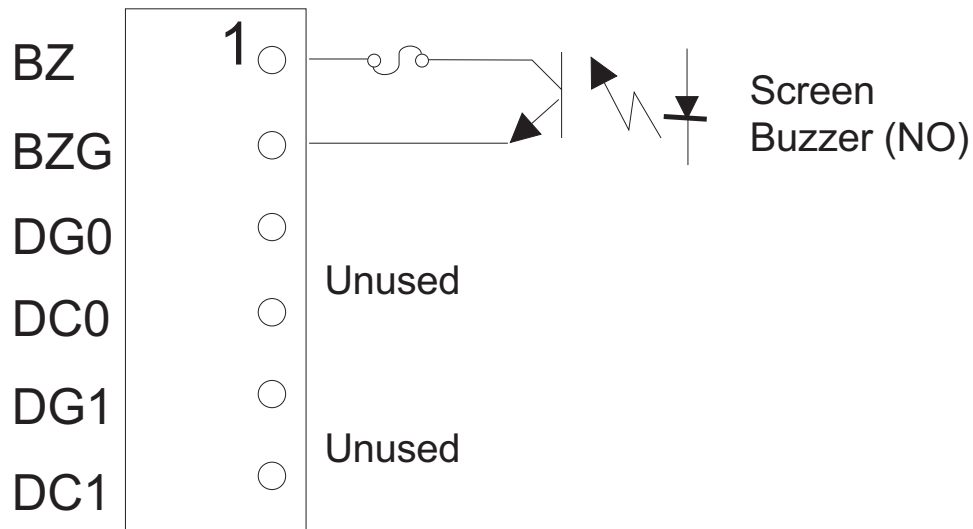
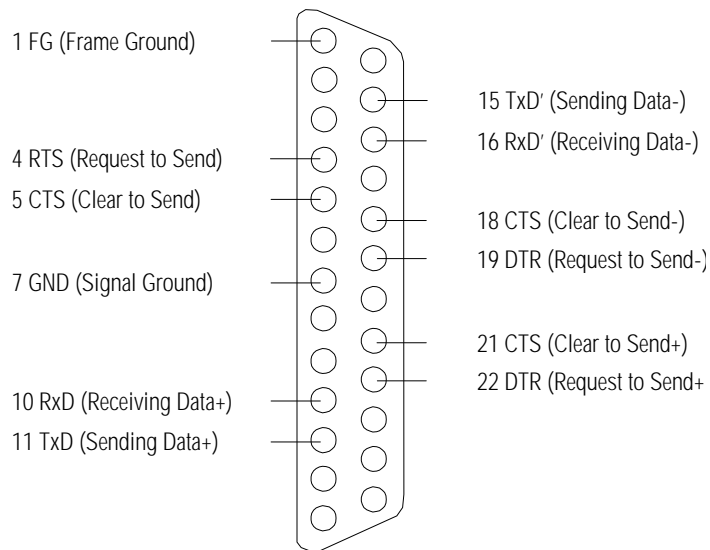

Figure 12, Hand Held QuickPanel 2 Buzzer Terminal Strip Schematic

3.2.8 QuickPanel 2 Serial Communications

The serial interface port (SIO on the cabinet mounted units, J2 on the Hand Held unit terminal block - TBC-QP2H) connects the QuickPanel 2 to your ORION motion controller. Refer to the following figure for the serial interface port (SIO/J2) connector pin description.



The CON-QPMOD8 connector adapter (shown in the figure in Section 3.5.1) is installed with 2.5 mm metric machine screws. Connection to the ORION is made by connecting a CBL-QPMOD8 cable between the SIO/J2 connector adapter (CON-QPMOD8) and an ORION Serial Port. Refer to the CON-QPMOD8 drawing in Appendix A for further information regarding the SIO/J2 connector adapter.

3.2.9 QuickPanel 2 TOOL Port

With ORMEC's family of QuickPanel 2 displays, the TOOL Port (CN2 on the Hand Held units) is used *only* for future maintenance or upgrade purposes (allowing you to download new operating system and serial communications driver software), for connection of a QuickPanel 2 external keypad (5" and 6" QuickPanel 2 units only), or for connection of a Laser Printer. Your QuickPanel 2 program (developed using QuickDesigner 2) is downloaded through the serial communications port (SIO/J2).

Upgrade of the QuickPanel 2 executive software should only be performed at the instruction of the ORMEC Service Department. Performing an upgrade of the QuickPanel 2 executive software erases the unit's program memory, and the QuickPanel 2 program will have to be downloaded from an ORION motion controller. Refer to the Upgrading the QuickPanel 2 Executive Software section of the Operation and Maintenance section for further information.

The TOOL port uses TTL signal levels and requires conversion to RS232, RS485 or other communication standard. The *QuickPanel 2 Executive Download cable* (CBL-QP2-AT/10) provided individually or with our QuickDesigner 2 Development Kit (MDK-QD2/3), converts these TTL signals to RS232 for connection to a Personal Computer (PC) through a standard 9-pin serial port.

The TOOL port connector is an 8-pin mini-DIN style. The port pin configuration and pin assignments are shown in the following drawing.

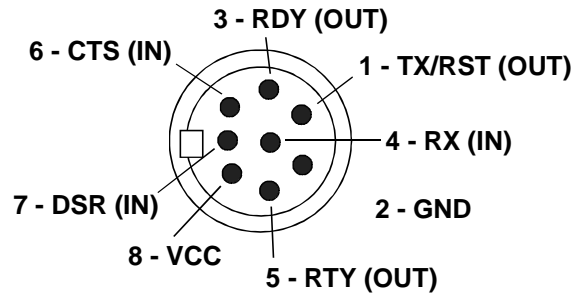

Figure 13, TOOL Port (TOOL)

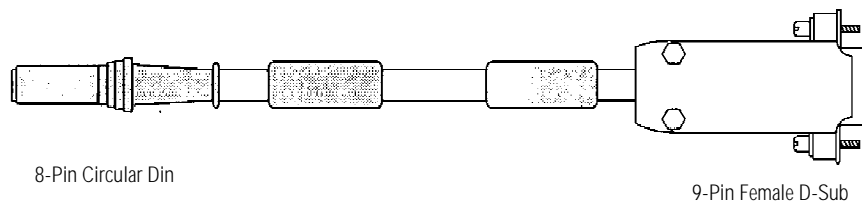

Figure 14, Executive Software Download Cable (CBL-QP2-AT/10)

3.3 NEMA 4X Bezels

NEMA 4X Bezels are available as an option for the cabinet mounted QuickPanel 2 family of displays used in harsh environments. A 4X appended to the cabinet mounted QuickPanel 2 model number (i.e. MMI-QP2/5MU4X) indicates that the unit is supplied with a NEMA 4X bezel.

3.3.1 NEMA 4X Bezel Mounting

The following diagram shows the basic elements of a bezel assembly. The basic assembly is the same for all cabinet mounted QuickPanels. The display is clamped to the stainless steel bezel by means of a clamp bracket. A full size gasket seals the display to the bezel, and also seals the bezel assembly to the panel. The bezel is secured to the panel by 10-32 x 0.5" threaded studs and nuts.

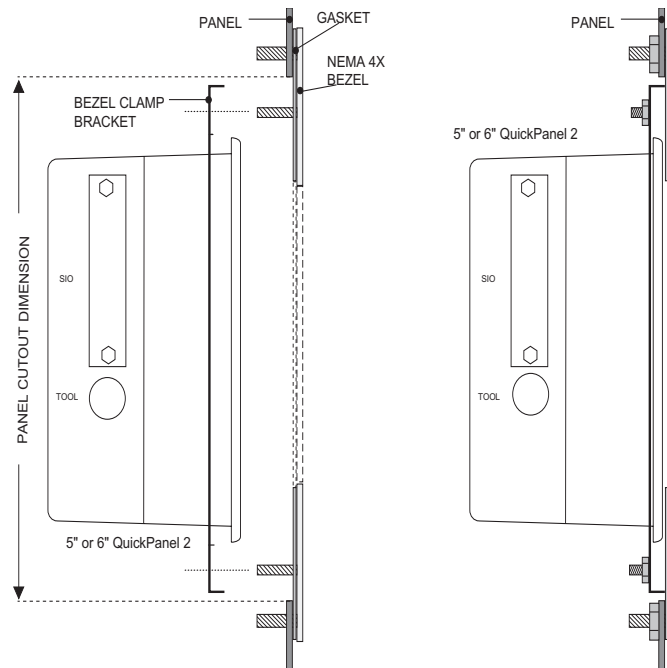

Figure 15, NEMA 4X Bezel Mounting Diagram

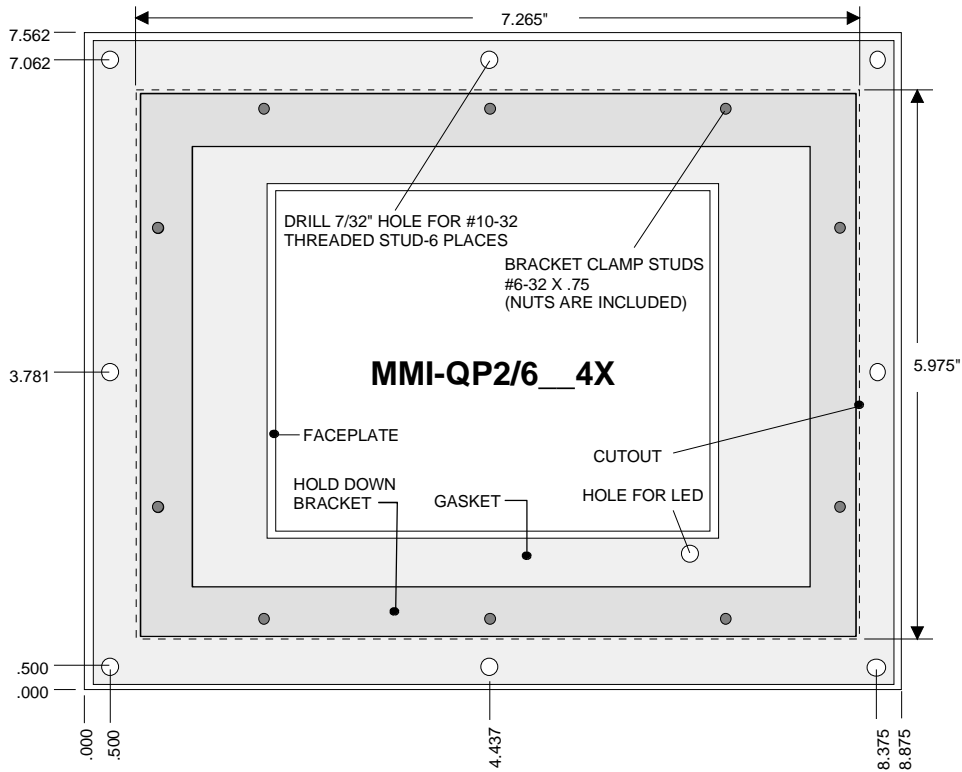

Figure 17, 6" QuickPanel 2 (MMI-QP2/6_4X) NEMA 4X Bezel Mounting Dimensions

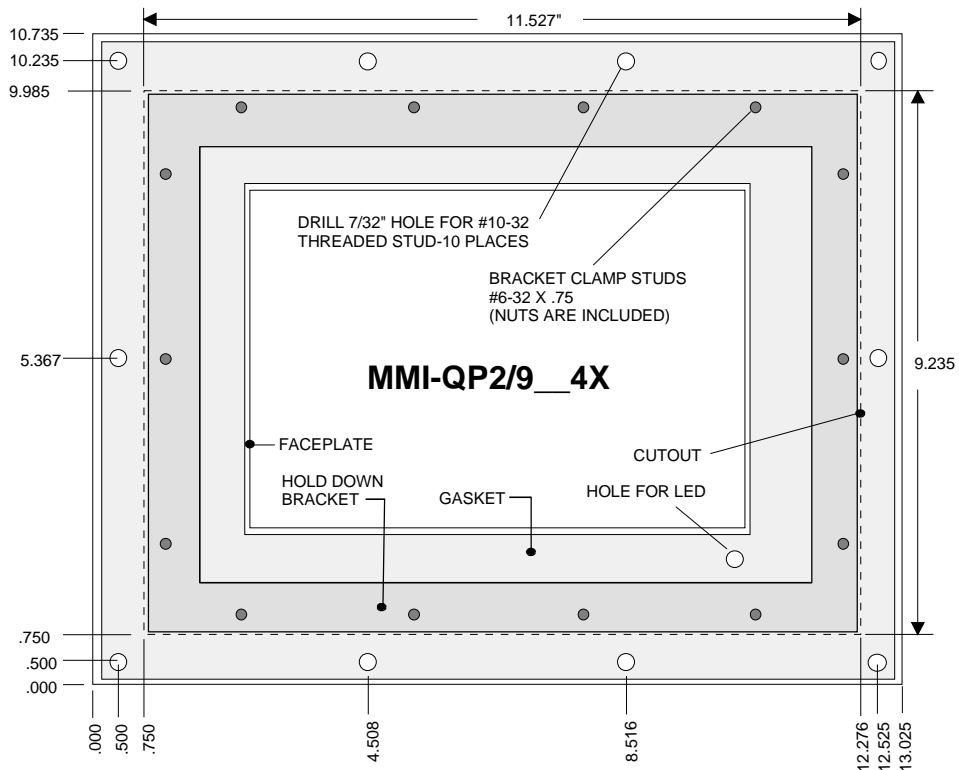

Figure 18, 9" EL QuickPanel 2 (MMI-QP2/9E_4X) NEMA 4X Bezel Mounting Dimensions

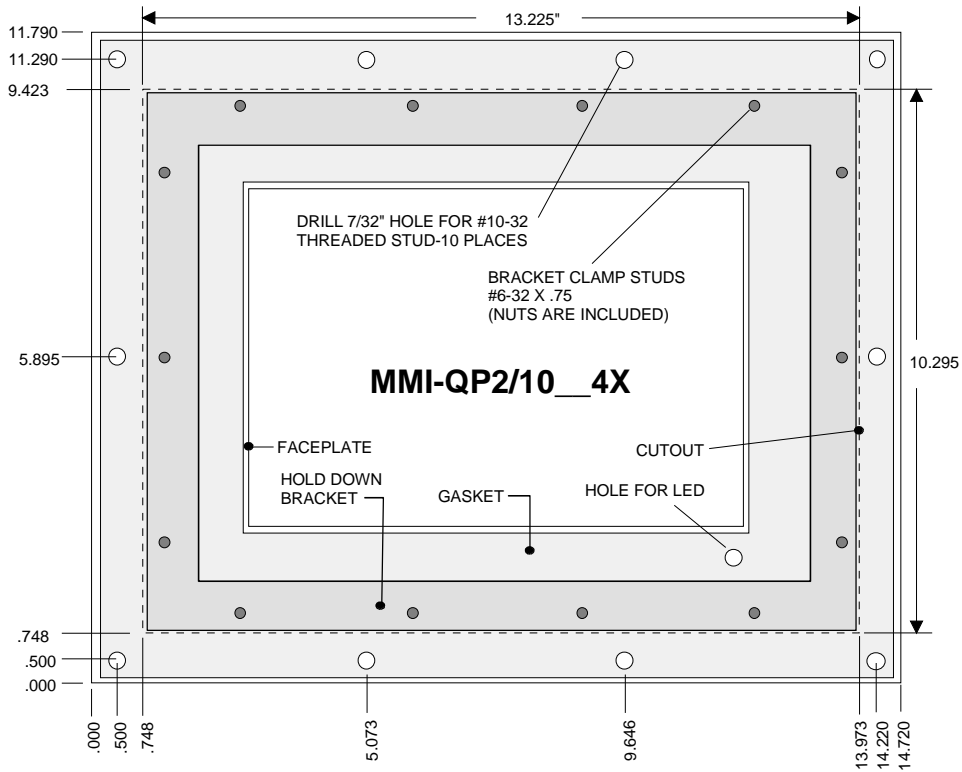

Figure 19, 10.5" QuickPanel 2 (MMI-QP2/10_4X) NEMA 4X Bezel Mounting Dimensions

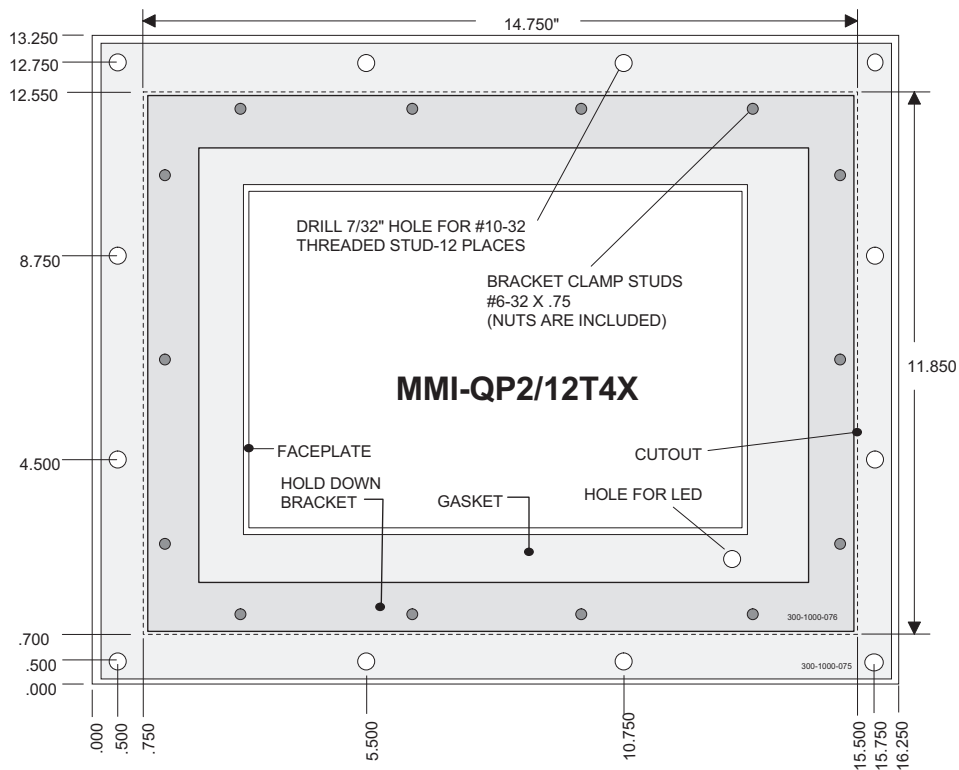

Figure 20, 12.1" QuickPanel 2 (MMI-QP2/12T) NEMA 4X Bezel Mounting Dimensions

3.4 Keypad Installation

The QuickPanel 2 Keypad allows operators to use a cabinet mounted 5" or 6" QuickPanel without using the touch screen for pressing buttons, entering data, etc. This can be a valuable feature for QuickPanels used in harsh environments, or when operators prefer using an operator interface terminal with tactile feedback.

The Keypad assembly, shown in Figure 21, consists of a faceplate with a data entry keypad and function keys, neoprene gasket, six threaded mounting posts with nuts, two mounting bars with screws, and a short interconnection cable.

The QuickPanel application program must be configured in QuickDesigner to use the Keypad. For further information regarding programming your QuickPanel application to work properly with a Keypad, refer to the QuickDesigner Help.

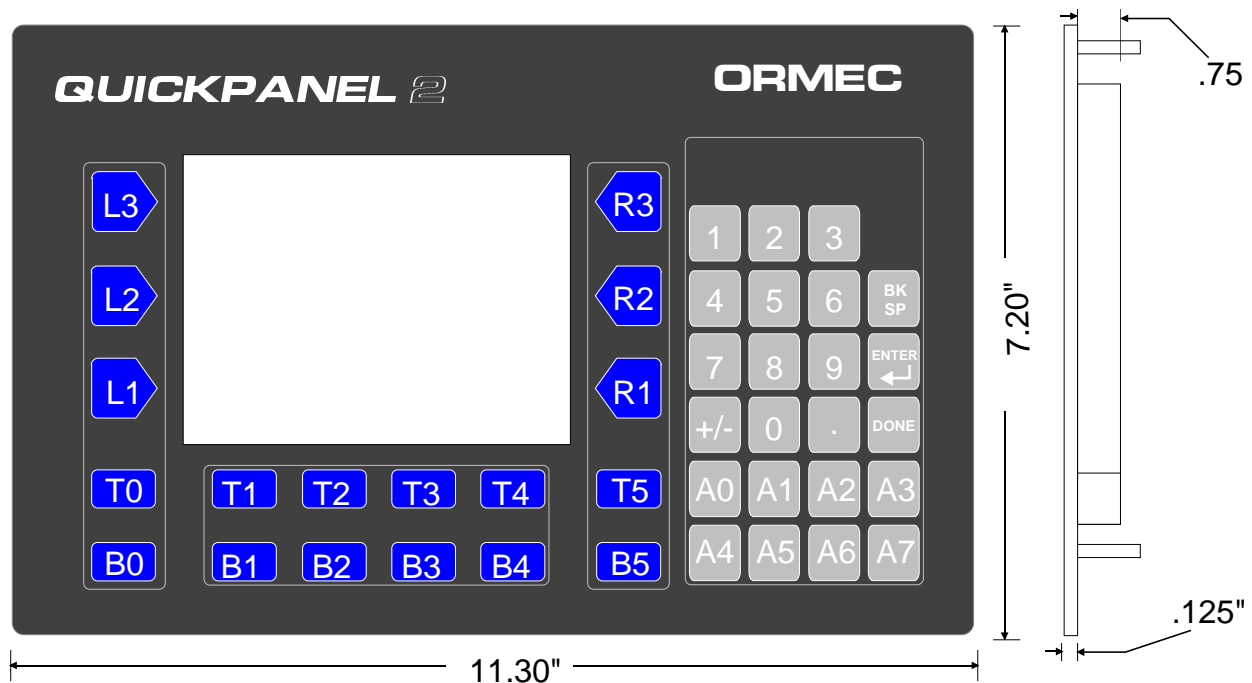

Figure 21, QuickPanel 2 Keypad Mounting Dimensions

3.4.1 Keypad Mounting

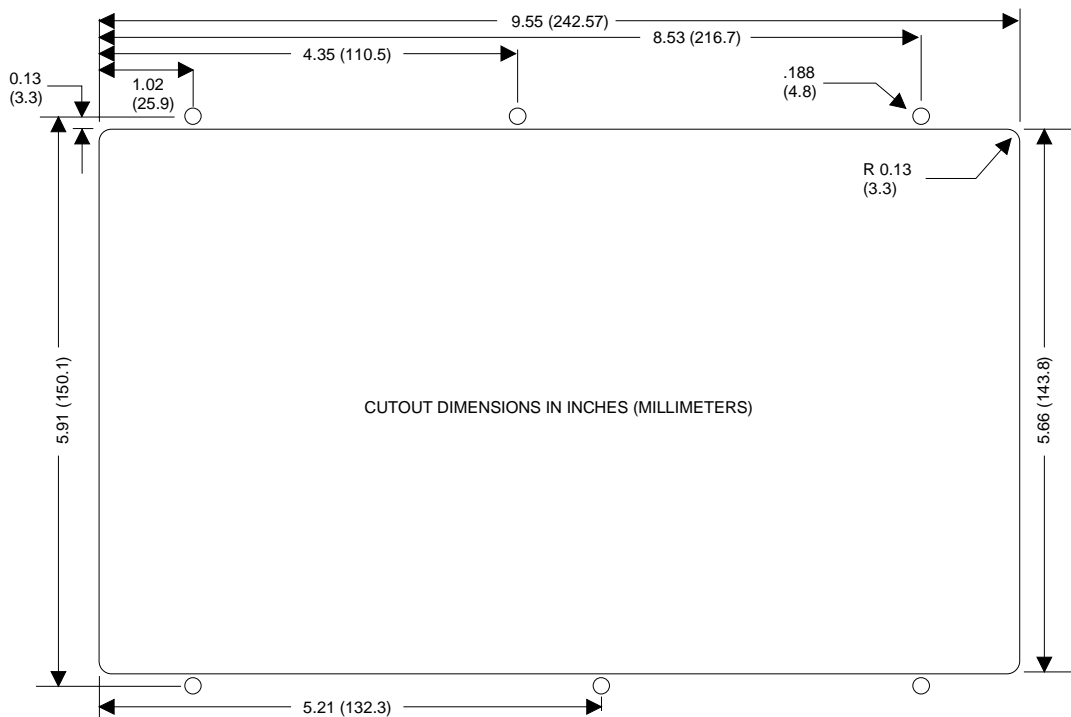

Figure 22, Keypad Mounting Cutout Dimensions

To mount a QuickPanel 2 unit in an enclosure panel:

- 1) Make the panel cutout as shown in Figure 22.
- 2) If the Keypad is to be used with a 5" QuickPanel, skip this step, and continue with step 3. If the Keypad is to be used with a 6" QuickPanel (MMI-QP2/6__), remove the 5" QuickPanel display mask from the Keypad window, as shown in Figure 23.
- 3) Remove the mounting bars from the back of the Keypad, as shown in Figure 24.
- 4) Place the QuickPanel in the Keypad window, replace the mounting bars and finger tighten the screws. The mounting bars should be pressed against the top and bottom of the QuickPanel, as shown in Figure 24.
- 5) Align the QuickPanel such that the entire display can be viewed through the Keypad Window, and tighten the mounting bars using a screwdriver, as shown in Figure 24.
- 6) Insert the Keypad into the cutout and attach it to the panel using the six threaded standoffs and nuts.
- 7) Attach the QuickPanel TOOL port to the Keypad port labeled "CONNECT TO QP TOOL PORT" using the interconnection cable provided, as shown in Figure 23.

- 8) Connect the power wiring and serial communications cable to the QuickPanel as described in the 5" and 6" QuickPanel 2 Rear View and Power Wiring sections of this chapter. NOTE: The Keypad gets its power supply from the QuickPanel, through the interconnection cable. No other cabling for the Keypad is required.

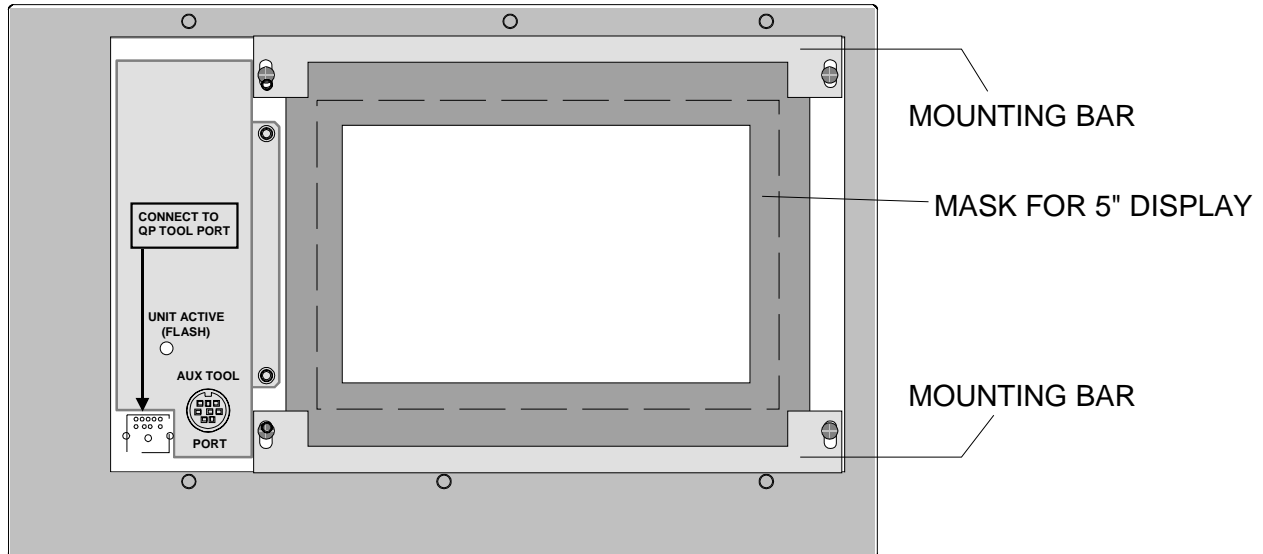

Figure 23, Keypad Rear View (Before QuickPanel Installation)

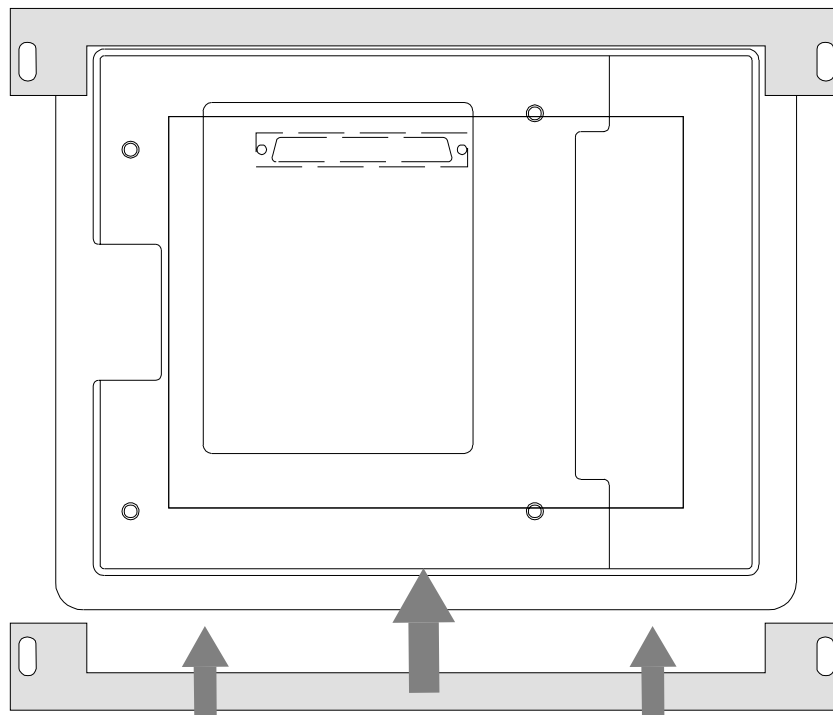

Figure 24, QuickPanel Keypad Mounting Bars

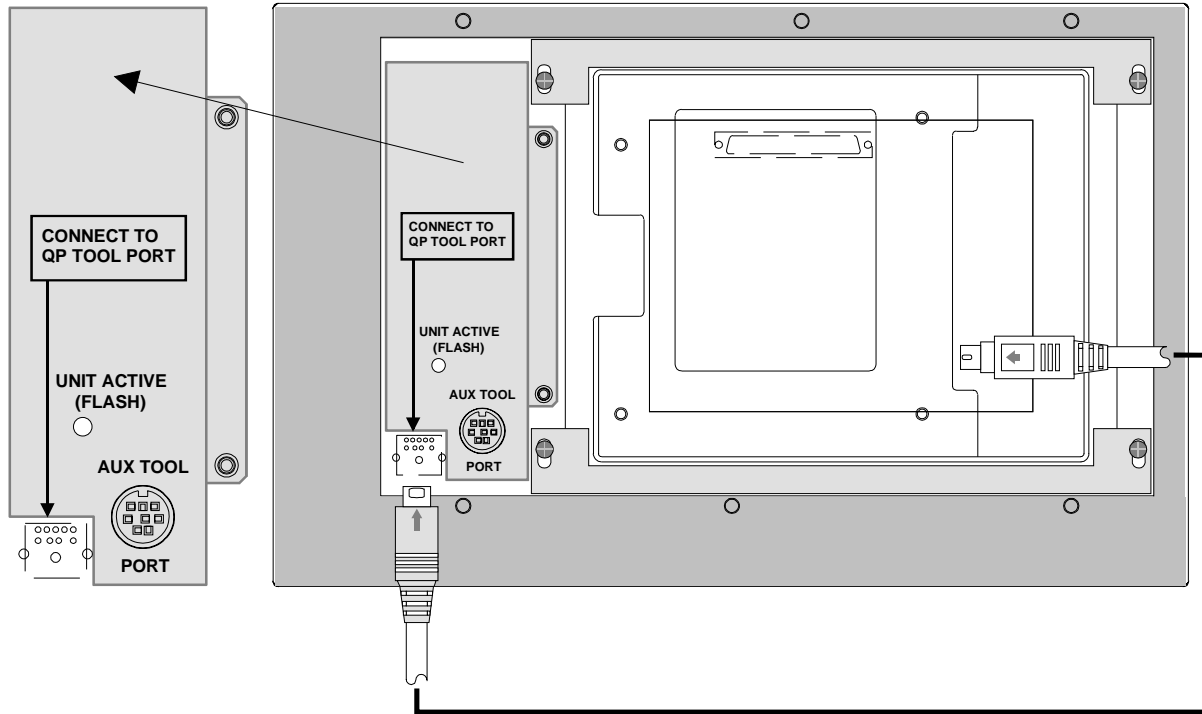

Figure 25, Keypad Rear View (After QuickPanel Installation)

3.4.2 Keypad Beep Configuration

The Keypad beep is configured ON at the factory prior to shipment. It can be disabled by removing the jumper from header JU2 on the back of the keypad.

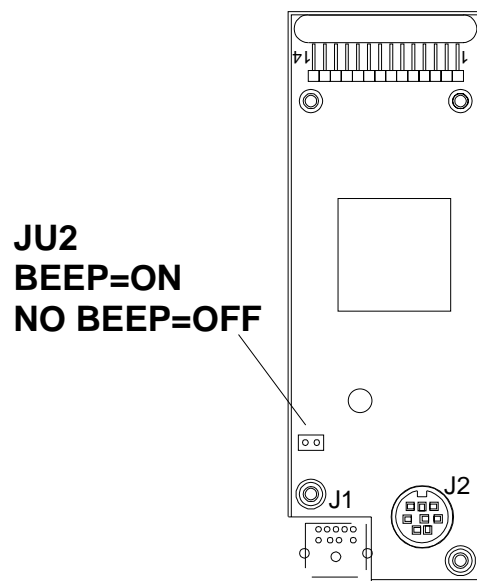

Figure 26, Keypad Rear View (with back cover removed)

- 1) Disable power to the QuickPanel.
- 2) Using a screwdriver, remove the two screws holding the back cover on the Keypad, and carefully remove the back cover itself, as shown in Figure 25.
- 3) Remove the jumper from header JU2, as shown in Figure 26.
- 4) Carefully replace the Keypad back cover and screws. When properly installed, the UNIT ACTIVE LED will extend through the Keypad back cover. CAUTION: Be sure not to pinch the ribbon cable while replacing the Keypad back cover.

3.4.3 Changing the Keypad Function Key Labels

The Keypad function key labels can be removed through thin slots in the back of the unit. There are four separate function key labels, one each for the keypad, the row of function keys on each side of the Keypad window, and the double row of function keys below the Keypad window.

CAUTION: Be extremely careful not to damage the Keypad or the labels themselves when removing the function key labels from the Keypad.

Chapter 4

Operation, Maintenance & Troubleshooting

4 Operation, Maintenance & Troubleshooting

4.1 Powerup Operation

At powerup the QuickPanel 2 performs system diagnostic tests. When the powerup diagnostic test are complete, the unit will begin executing the application program and either display the Default Panel (as defined in QuickDesigner 2) or prompt the operator to press a button to display the first panel (the panel with the lowest ID number). New QuickPanels are shipped from the factory with the operating system and a simple application program already installed in them, no other preliminary setup is required.

If a QuickPanel 2 does not have a valid program in it's Flash memory, one must be loaded into it before program downloads from the ORION controller can be executed using the QP.DNLD command. Refer to the Upgrading the Operating System Software section for further information.

4.2 QuickPanel 2 Program Download

QuickPanel 2 units are shipped from ORMEC with the latest version of the QuickPanel 2 operating system software installed, and an application program in the Flash memory. Once power is applied to the unit, it is ready for you to download your QuickPanel 2 application program from an ORION motion controller. Your MotionBASIC program can be written to automatically perform a program download to a QuickPanel 2 whenever the QuickPanel application program stored in the ORION is different than that stored in the QuickPanel. Refer to the QuickPanel 2 Communications MBX Help for further information regarding QuickPanel 2 communications and program download.

4.3 Upgrading the QuickPanel 2 Executive Software

QuickPanels are shipped from ORMEC with the latest version of the QuickPanel 2 operating system software already installed, and an application program in the Flash memory. At powerup the currently installed version of the ORION Serial Communications Driver (e.g. ORMEC V#.##) is briefly displayed. The operating system and ORION Serial Communications Driver versions are also displayed in the QuickCourier dialog box when performing a QuickPanel Direct Download.

The QuickPanel 2 Direct Download Utility (installed as part of the QuickDesigner 2 installation) allows the user to update the QuickPanel 2 operating system software by downloading an application program directly from their development computer into a QuickPanel using QuickCourier. The user can choose whether to simply download a QuickPanel application to a unit, or to update the operating system software and download a QuickPanel application.

If you have aborted a QuickPanel download from the ORION motion controller (by cycling the ORION and/or QuickPanel power during the download process) it is not necessary to update the QuickPanel operating system software. Using the QuickPanel 2 Direct Download Utility to only download a valid application program in the QuickPanel will allow it to function normally, and will require substantially less time than updating the operating system.

NOTE: Update of the QuickPanel 2 operating system software should only be performed at the instruction of the ORMEC Service Department.

Required Equipment

- An IBM-PC compatible computer operating Windows 3.x or Windows 95 with ORMEC's QuickDesigner 2 software installed.
- CBL-QP2-AT/10

Download Procedure

- 1) Apply power to the QuickPanel 2 unit.
- 2) Connect the CBL-QP2-AT/10 between the development computer 9-pin D-Sub serial port and the QuickPanel 2 8-pin DIN connector (TOOL). If your QuickPanel is attached to a Keypad, connect the CBL-QP2-AT/10 to the AUX. TOOL PORT on the back of the Keypad itself. If you are using a Hand Held QuickPanel, you will need to remove the back cover to access the TOOL port (CN2), refer to Figure 8 in the Installation chapter for further information. If your development computer has a 25-pin D-Sub serial port, you will need a 9 to 25-pin D-Sub adapter.
- 3) Execute the QuickDesigner 2 Direct Download Utility found in the ORMEC MotionDesk group in Windows.
- 4) Select the application in QuickManager you would like to download into the QuickPanel.

- 5) Verify in the QuickManager Project Setup dialog box that the appropriate Display Type is selected, the ORION Serial Protocol is specified as the PLC Type, and that the Serial Port parameters are 19200 baud, 8 data bits, 1 stop bit, no parity, with no handshaking. Refer to the QuickDesigner Help for further information.
- 6) Click the Download button in QuickManager, which will compile the application program and start QuickCourier. Refer to the QuickDesigner Help for further information.
- 7) Select the appropriate development computer serial port for the download in the Communications Port drop down list. The download process will begin as soon as communications is established with the QuickPanel 2.
- 8) If you need to update the operating system, click the Update Display Device Executable. You will then be instructed to cycle power to the QuickPanel 2. After the operating system is updated, the selected application program will then automatically be loaded into the QuickPanel Flash memory.

If you have any questions or problems regarding this procedure, please call the ORMEC Service Department at (716) 385-3520.

4.4 Replacing the Cabinet Mounted QuickPanel 2 Backlight Lamp

All the QuickPanel 2 displays, except the 9" EL units (MMI-QP2/9E_), have backlight lamps. The backlight is a small florescent tube mounted near the top of the display screen. Table 3 shows a cross reference between the various QuickPanel 2 model numbers and their corresponding replacement backlight lamp part numbers.

QuickPanel 2 Model Number	Replacement Backlight Lamp
MMI-QP2/5__	MMI-QP2-CCT/5
MMI-QP2/6__	MMI-QP2-CCT/6
MMI-QP2/10__	MMI-QP2-CCT/10
MMI-QP2/12T	MMI-QP2-CCT/12

Table 5, Replacement Backlight Lamp Part Numbers

NOTE: Hand Held QuickPanel 2 units are not field serviceable. If you need to replace the backlight lamp in a Hand Held QuickPanel 2, please call the ORMEC Service Department.

To replace a QuickPanel 2 backlight lamp:

- 1) **Turn OFF power to the QuickPanel 2, and allow the unit to cool before removing the backlight lamp. High voltage power is present whenever the QuickPanel power is ON.**
- 2) Disconnect the power wiring and serial communications cabling from the QuickPanel 2, and remove it from the enclosure mounting panel.

- 3) Place the unit face down on a smooth flat surface which will not scratch the front of the QuickPanel 2.
- 4) Using a small screwdriver, remove the screws as indicated below for the appropriate unit type.
 - 5" & 6" Units: Two screws on the top of the unit.
 - 9" EL Units: Two screws in the upper corners of the rear of the unit.
 - 10.5" Units: Six screws total, two on top and four in the upper corners and bottom middle of the rear of the unit.
 - 12.1" Units: Four screws, one in each corner of the rear of the unit.
- 5) Slowly pivot the rear portion of the QuickPanel 2 open.
- 6) Disconnect the lamp connector.
- 7) Remove the clamp screw from the left side of the lamp, and remove the lamp itself. NOTE: The lamp is press fit into the unit, and may require some small force to remove.
- 8) Insert and reconnect the new lamp.
- 9) Close the rear cover, and reinsert the screws. CAUTION: Be careful not to pinch any wiring between the front of the QuickPanel 2 and it's rear cover.
- 10) Remount the QuickPanel 2 in the enclosure panel.
- 11) Reconnect the power wiring and serial communications cabling. Refer to the Installation chapter for further information.

4.5 Replacing the Cabinet Mounted QuickPanel 2 Touch Screen Overlay

The QuickPanel 2 touch screen overlay is made of a tough, flexible material which can withstand exposure to a variety of chemicals and hard use. After a long period of use, the touch screen overlay may get scratched or otherwise damaged and may need to be replaced. Table 4 shows a cross reference between the various QuickPanel 2 model numbers and their corresponding replacement touch screen overlay part numbers.

Protective cover sheets can be used to prevent the QuickPanel 2 touch screen overlay from becoming scratched. Refer to the QuickPanel 2 Protective Cover Sheets section of this chapter for further information.

QuickPanel 2 Model Number	Touch Screen Overlay
MMI-QP2/5__	MMI-QP2-SCN/5
MMI-QP2/6__	MMI-QP2-SCN/6
MMI-QP2/10__	MMI-QP2-SCN/10

Table 6, Replacement Touch Screen Overlay Part Numbers

NOTE: Hand Held QuickPanel 2 units are not field serviceable. If you need to replace the touch screen overlay on a Hand Held QuickPanel 2, please call the ORMEC Service Department.

To replace a QuickPanel 2 touch screen overlay:

- 1) **Turn OFF power to the QuickPanel 2. High voltage power is present whenever the QuickPanel power is ON.**
- 2) Starting in the lower left corner, peel up the corner of the overlay using a small pick.
- 3) Carefully remove the touch screen overlay from the unit. NOTE: A label is covers the touch screen overlay, removing the overlay also removes this label.
- 4) Remove the backing material from the new replacement touch screen overlay.
- 5) Align the replacement overlay on the unit, making sure that the LED hole is placed over the POWER LED. CAUTION: The replacement touch screen overlay has a very aggressive adhesive, and will be difficult to remove without damaging if misaligned.
- 6) Press the replacement touch screen overlay in place.

4.6 Installing QuickPanel 2 Protective Cover Sheets

Protective cover sheets are available to help minimize the wear and tear on the QuickPanel touch screen overlay associated with use in a harsh environment. The protective cover sheets are clear cover sheets (20 per package for 5" & 6" units, and 10 per package for 9", 10.5" & 12.1" units) which are placed over the QuickPanel 2 touch screen. As it becomes difficult to view the screen, the protective cover sheet can be peeled off and replaced with a new one. Table 5 shows a cross reference between the various QuickPanel 2 model numbers and their corresponding protective cover sheet part numbers.

<u>QuickPanel 2 Model Number</u>	<u>Protective Cover Sheets</u>
MMI-QP2/5__	MMI-QP2-COV/5
MMI-QP2/6__	MMI-QP2-COV/6
MMI-QP2/9__	MMI-QP2-COV/9
MMI-QP2/10__	MMI-QP2-COV/10
MMI-QP2/12T	MMI-QP2-COV/12

Table 7, Protective Cover Sheets Part Numbers

To install the protective cover sheet, simply align it over the QuickPanel 2 viewing area and press into place.

4.7 QuickPanel Error Messages & Troubleshooting

This section explains the various QuickPanel error messages, and how to correct the problems they indicate. After correcting the problem, it may be necessary to cycle power on the QuickPanel to remove the error message.

4.7.1 PLC COM. ERROR (02:FA, FB, FC, 51)

Indicates a fault in the QuickPanel device driver software configuration or tag address configuration.

PLC COM. ERROR (02:FA)

This error occurs when the address set for a tag is out of the allowable range. Determine which tag is incorrectly configured, correct it, and re-download the application.

PLC COM. ERROR (02:FB)

This error occurs when the address for a tag is no longer valid in the ORION, usually as a result of issuing the MotionBASIC CLEAR command and not restoring the variable mappings. Change your application program so that it executes the appropriate MAP statements after executing a CLEAR command.

PLC COM. ERROR (02:FC)

This error occurs when the communications settings between the ORION and the QuickPanel do not match. Correct the serial communications port parameter settings, and re-download the application using the QuickDesigner 2 Direct Download utility.

PLC COM. ERROR (02:51)

This error occurs when the address set for a tag is out of the allowable range. Determine which tag is incorrectly configured, correct it, and re-download the application.

If these steps do not resolve the problem, contact the ORMEC Service Department at (716) 385-3520.

4.7.2 RECEIVE DATA ERROR (02:FD)

This error message occurs when there is a problem with the data sent to the QuickPanel, usually as a result of an exception response from the ORION.

Verify that all the tag variables for the objects on the currently displayed QuickPanel screen have corresponding MAP statements linking them to MotionBASIC variables in the ORION's MotionBASIC application program.

Verify that 32 bit data (long integers, floating point, and set data) or string data tag variables have all the required MAP Reference Numbers properly

configured. NOTE: These types of variables require 2 or more MAP Reference Numbers per tag variable.

If these steps do not resolve the problem, contact the ORMEC Service Department at (716) 385-3520.

4.7.3 PLC NOT RESPONDING (02:FE)

This error occurs when there is a reply timeout.

Verify that the ORION power is on, which is indicated by the flashing Watchdog OK LED on the front of the unit.

Verify that the communications cable (CBL-MOD8) and adapter connector (CON-QPMOD8 Rev. B) are properly connected to the QuickPanel.

Verify that the communications cable (CBL-MOD8) is connected to the appropriate serial port (i.e. SRL1, SRL2, etc.) on the ORION.

Verify that the ORION QuickPanel communications have been enabled in the MotionBASIC application program. Refer to the QuickPanel Communications MotionBASIC Extension (MBX-QP) for further information.

If PLC NOT RESPONDING message is flashing at the QuickPanel communications timeout rate (Project | Setup | Protocol), which is configured for 3 seconds default, the QP.OPEN statement has not been executed.

If the PLC NOT RESPONDING message is flashing at a high rate, the QP.OPEN statement has been executed, but the QP@ variable is not set to ON.

If these steps do not resolve the problem, contact the ORMEC Service Department at (716) 385-3520.

4.7.4 PLC NOT CONNECTED (02:FF)

This error occurs when there is a problem with the QuickPanel's serial communications hardware handshaking lines.

Verify that the serial communications adapter connector (CON-QPMOD8 Rev. B) is properly connected to the QuickPanel.

If this does not resolve the problem, contact the ORMEC Service Department at (716) 385-3520.

4.7.5 SYSTEM ERROR

Indicates a fault in the QuickPanel operating system or device driver software. An error code in one of the two formats shown below will appear following the error message.

SYSTEM ERROR (03:xx)

Re-download the application program directly from the development PC using the QuickDesigner 2 Direct Download utility. If problem persists, download the application program and the QuickPanel executable software (click on the "Update display device executable" box in QuickCourier).

SYSTEM ERROR (xxx:xxx:xxx)

Download the application program and the QuickPanel executable software (click on the "Update display device executable" box in QuickCourier) directly from the development PC using the QuickDesigner 2 Direct Download utility.

If you power down the QuickPanel 2 during a memory operation (i.e. FORMATTING or WRITING), you may generate this error. On subsequent power ups the unit will issue a prolonged beep and enter the system diagnostics routines. To reset the memory:

MAIN MENU - Press button #1, "INITIALIZE", this will generate the following message, "NEED TO INITIALIZE INTERNAL MEMORY. PRESS ANY KEY". Press the "INITIALIZE" button again.

INITIALIZE - Press button #4, "INITIALIZE MEMORY".

INITIALIZE MEMORY - You will be prompted to enter a password, type 1 1 0 1, and press "START". The unit will display the flashing FORMATTING message.

INITIALIZE - Cycle power -OR - Press the MAIN MENU tab, then press button #4, "RUN".

Using the QUICKDesigner 2 Direct Download utility, reload your application program.

If these steps do not resolve the problem, contact the ORMEC Service Department at (716) 385-3520.

4.7.6 UNSUPPORTED TAG IN SCREEN DATA

This error occurs when there is an improperly defined tag variable in the QuickPanel.

Note the screen on which the error is displayed, and verify in QuickDesigner that all the tag variables on that screen as well as the Panel Trigger tag are properly defined.

If this does not resolve the problem, contact the ORMEC Service Department at (716) 385-3520.

4.7.7 ILLEGAL ADDRESS IN SCREEN DATA

This error occurs when a tag is configured as a read only variable on one QuickPanel screen, and a read-write variable on another. An example of this would be configuring a tag as an Alarm tag, and setting up a Numeric Data Entry button to write to the same tag.

Determine which tag(s) are the source of the problem and change them

If this does not resolve the problem, contact the ORMEC Service Department at (716) 385-3520.

4.7.8 SCREEN MEMORY DATA IS CORRUPT

This error occurs when the checksum of the QuickPanel screen memory data is incorrect because of a corruption in the screen files. The SCREEN MEMORY DATA IS CORRUPT is preceded by a SCREEN MEMORY CHECKSUM ERROR.

Re-download the application program and executable software (by clicking the "Update display device executable" box in QuickCourier) using the QuickDesigner 2 Direct Download utility.

4.7.9 CLOCK SETUP ERROR

This error occurs when the backup battery for the internal QuickPanel clock is dead.

Call the ORMEC Service Department at (716) 385-3520 to obtain a replacement battery.

After replacing the battery you will need to set the internal clock.

4.7.10 SCREEN TRANSFER ERROR

This error occurs when there was a problem downloading the screen data into the QuickPanel. Re-download the application program using the QuickDesigner 2 Direct Download Utility.

If this does not resolve the problem, contact the ORMEC Service Department at (716) 385-3520.

4.8 QuickPanel Display Troubleshooting

4.8.1 Not all Panel Objects are Displayed

In order for all objects on a panel to be properly displayed, it is necessary to have all their corresponding tags mapped in the ORION. Not having tags mapped in the ORION normally results in a RECEIVE DATA ERROR (02:FD). If a QuickPanel has many object tags with only one not mapped, the RECEIVE DATA ERROR message may not be displayed long enough for the operator to read it. This gives the appearance of the objects not being displayed properly on the QuickPanel.

Verify that all the appropriate tags are mapped in the ORION.

Chapter 5

Specifications

5 Specifications

5.1 General Specifications

Touch Panel Type	Analog Resistive
-------------------------	------------------

5.2 Mechanical and Environmental Specifications

	Cabinet Mounted Units	Hand Held Units
Installation	Front mount	Self-enclosed
Cooling	Natural convection	Natural convection
Vibration	10 to 25 Hz 2G on each X, Y, Z 30 min.	10 to 25 Hz 2G on each X, Y, Z 30 min.
Temperature		
Operating	0 to 50C	0 to 40C
Storage	-10 to 60C	-20 to 60C
Relative Humidity		
Operating	20 to 85% non-condensing	20 to 85% non-condensing
Storage	5 to 85% non-condensing	5 to 85% non-condensing
Enclosure Ratings	NEMA 13/4X ¹ IP65	NEMA 1 IP63

¹ All QuickPanel 2 units are designed for use in NEMA 13/4X applications.

5.3 Power Specifications

Power Failure Immunity	20 msec max.
Withstand Voltage	1500 VAC (10 mA max., 1 min.)
Insulation	10M ohms @ 500 VDC
Noise Immunity	1000 V (pk-pk) 1 usec pulse

5.4 Unit Specifications

	MMI-QP2/5M_	MMI-QP2/5C_	MMI-QP2/6M_	MMI-QP2/6C_
Input Voltage	20.4 - 27.6 VDC	20.4 - 27.6 VDC	20.4 - 27.6 VDC	20.4 - 27.6 VDC
Input Power	12 watts max. (500 mA nom.)	15 watts max. (625 mA nom.)	12 watts max. (500 mA nom.)	15 watts max. (625 mA nom.)
Display Type	LCD (mono)	Dual Scan STN Color	LCD (mono)	Dual Scan STN Color
Viewing Area	4.0" W x 3.0" H 5.0" diagonal	4.0" W x 3.0" H 5.0" diagonal	5.0" W x 4.0" H 6.0" diagonal	5.0" W x 4.0" H 6.0" diagonal
Pixel Resolution	320W x 240H	320W x 240H	320W x 240H	320W x 240H
Touch Resolution	15W x 11H	15W x 11H	15W x 11H	15W x 11H
Colors	White/Grey + Flash	8 solid + 8 flash	White/Grey + Flash	8 solid + 8 flash
Weight	1.54 lbs (0.7 kg)	1.54 lbs (0.7 kg)	1.54 lbs (0.7 kg)	1.54 lbs (0.7 kg)
Program Memory	224K bytes	224K bytes	896K bytes	896K bytes
	MMI-QP2H/6MU	MMI-QP2H/6CU		
Input Voltage	20.4 - 27.6 VDC	20.4 - 27.6 VDC		
Input Power	12 watts max. (500 mA nom.)	15 watts max. (625 mA nom.)		
Display Type	LCD (mono)	Dual Scan STN Color		
Viewing Area	5.0" W x 4.0" H 6.0" diagonal	5.0" W x 4.0" H 6.0" diagonal		
Pixel Resolution	320W x 240H	320W x 240H		
Touch Resolution	15W x 11H	15W x 11H		
Colors	White/Grey + Flash	8 solid + 8 flash		
Weight	1.9 lbs (0.87 kg)	1.9 lbs (0.87 kg)		
Program Memory	896K bytes	896K bytes		

	MMI-QP2/9E	MMI-QP2/9EU MMI-QP2/9EE	MMI-QP2/10MU MMI-QP2/10ME	
Input Voltage	85-135 VAC, 50/60 Hz.	20.4 - 27.6 VDC	20.4 - 27.6 VDC	
Input Power	50 VA max.	50 watts max. (2.1 amps nom.)	50 watts max. (2.1 amps nom.)	
Display Type	EL (mono)	EL (mono)	LCD (mono)	
Viewing Area	7.7" W x 4.8" H 9.0" diagonal	7.7" W x 4.8" H 9.0" diagonal	8.5" W x 6.3" H 10.5" diagonal	
Pixel Resolution	640W x 400H	640W x 400H	640W x 480H	
Touch Resolution	32W x 20H	32W x 20H	32W x 24H	
Colors	Amber + Flash	Amber + Flash	White/Black + Flash	
Weight	4.4 lbs (2 kg)	4.4 (2 kg)	6.6 lbs (3 kg)	
Program Memory	896K bytes	896K bytes	896K bytes	
	MMI-QP2/10C	MMI-QP2/10CU MMI-QP2/10CE	MMI-QP2/10T	MMI-QP2/10TU MMI-QP2/10TE
Input Voltage	85-135 VAC, 50/60 Hz.	20.4 - 27.6 VDC	85-135 VAC, 50/60 Hz.	20.4 - 27.6 VDC
Input Power	50 VA max.	50 watts max. (2.1 amps nom.)	50 VA max.	50 watts max. (2.1 amps nom.)
Display Type	Dual Scan LCD (Color)	Dual Scan LCD (Color)	Active TFT LCD (Color)	Active TFT LCD (Color)
Viewing Area	8.5" W x 6.3" H 10.5" diagonal	8.5" W x 6.3" H 10.5" diagonal	8.5" W x 6.3" H 10.5" diagonal	8.5" W x 6.3" H 10.5" diagonal
Pixel Resolution	640W x 480H	640W x 480H	640W x 480H	640W x 480H
Touch Resolution	32W x 24H	32W x 24H	32W x 24H	32W x 24H
Colors	8 solid + 8 flash	8 solid + 8 flash	8 solid + 8 flash	8 solid + 8 flash
Weight	6.6 lbs (3 kg)	6.6 lbs (3 kg)	6.6 lbs (3 kg)	6.6 lbs (3 kg)
Program Memory	896K bytes	896K bytes	896K bytes	896K bytes

	MMI-QP2/12T
Input Voltage	85-135 VAC, 50/60 Hz.
Input Power	50 VA max.
Display Type	Active TFT LCD (Color)
Viewing Area	9.7" W x 7.6" H 10.5" diagonal
Pixel Resolution	800W x 600H
Touch Resolution	40W x 30H
Colors	8 solid + 8 flash
Weight	8.4 lbs (3.8 kg)
Program Memory	896K bytes

5.5 European Union Ratings

All QuickPanel units with the CE Mark (model numbers listed below) have been tested to European Union directives EN50082-2:1995, EN55022 Class A (94).

MMI-QP2/5_E
MMI-QP2/6_E
MMI-QP2/9EE
MMI-QP2/10_E

5.6 UL Approval

All QuickPanel units with UL Approval (model numbers listed below) are approved for use in Class 1, Division 2, Groups A, B, C, and D applications (except for MMI-QP2/6_U units, which have UL Approval but not for Hazardous Locations).

MMI-QP2/5_U
MMI-QP2/6_U (not UL Approved for Hazardous Locations)
MMI-QP2/9EU
MMI-QP2/10CU
MMI-QP2/10TU

Full UL Approval for the MMI-QP2/6_U and MMI-QP2/10MU units is pending, call your ORMEC Sales Representative for further information.

5.7 Chemical Resistance Chart

The following chart lists the materials used in the construction of QuickPanel 2 units, and rates their resistance, or susceptibility, to chemicals commonly encountered in an industrial environment. The information contained in this chart is based on data supplied by the manufacturers of the various materials, and is believed to be accurate. The temperature, concentration, or combination with other chemicals can affect the way in which a particular chemical reacts with a given material. Thus, this chart should only be used as a general guide and not as an unqualified authority. All of the material resistance's or susceptibilities listed assume normal QuickPanel operating temperatures. Additionally, one must be aware that if a protective coating on a particular material is damaged, the substrate may be adversely affected by an otherwise non-reactive chemical.

An **Acceptable Resistance (A)** rating means that the chemical may remain in contact with the exposed material indefinitely with no appreciable degradation of the exposed material.

A **Moderate Resistance (M)** rating means that the chemical will not cause any appreciable degradation of the exposed material on an intermittent basis or that only minor degradation will occur that will not impair the performance of the material.

An **Unacceptable Resistance (U)** rating means that the chemical will degrade the performance of the exposed material to such a degree that the material no longer performs as designed.

A **Not Tested (T)** rating means that the exposed material has not been tested for resistance to a particular chemical.

A = Acceptable Resistance M = Moderate Resistance U = Unacceptable Resistance T = Not Tested	NEMA 4X Bezel	NEMA 4X Gasket	O-Ring Gasket	Keypad	Plastic Housing	Touch Screen
1,1,1 trichlorethane	A	T	U	T	T	T
acetaldehyde	A	T	M	A	U	T
acid, 10% acetic	T	A	T	M	M	M
acid, 10% hydrochloric	U	A	A	A	A	M
acid, 10% nitric	A	A	M	M	M	M
acid, 10% sulfuric	U	A	U	T	M	M
acid, concentrated acetic	T	A	M	U	T	U
acid, concentrated hydrochloric	U	A	T	U	T	U
acid, concentrated sulfuric	U	A	U	U	T	U
acid, potassium	T	A	T	T	T	T
alcohol, benzyl	A	T	M	T	T	T
aliphatic hydrocarbons	T	A	T	A	T	T

A = Acceptable Resistance M = Moderate Resistance U = Unacceptable Resistance T = Not Tested	NEMA 4X Bezel	NEMA 4X Gasket	O-Ring Gasket	Keypad	Plastic Housing	Touch Screen
amines	A	T	M	T	T	T
ammonia, 10%	T	T	T	U	T	M
ammonia, concentrated	M	T	T	U	T	U
ammonium hydroxide	A	A	A	T	M	T
aromatic hydrocarbons	T	M	U	T	T	T
benzene	A	M	U	A	U	A
brake fluid	A	T	T	T	U	T
carbon tetrachloride	M	T	T	T	U	T
chloroform	A	T	U	T	U	M
diethyl ether	T	T	T	A	T	T
esters	T	T	T	T	T	T
ethylene chloride	A	T	U	T	U	T
gasoline	A	A	U	T	U	T
halogenated hydrocarbons	T	T	T	T	T	T
jet fuel	A	A	U	T	T	T
kerosene	A	A	A	T	T	T
lacquer thinner	T	T	A	T	T	U
methanol	A	T	A	A	U	T
nitric acid ethyl	T	A	T	T	T	M
ozone	T	A	T	T	T	T
perchlorethylene	T	T	U	T	T	T
petrol	A	A	T	A	T	T
phenol	A	T	U	T	U	T
toluene	A	T	U	A	U	A
trichlorethylene	A	T	U	A	T	T
turpentine	A	M	U	A	U	T
xylol	T	T	T	T	T	T
acetone	A	T	A	A	U	A
alcohol, ethyl	A	T	M	A	U	T
alcohol, isopropyl	A	T	A	A	U	T
alkalis	T	A	T	M	M	U
butyl cellosolve	T	T	T	T	T	T
caustic soda, 10%	A	A	A	U	A	U
caustic soda, 40%	A	A	T	U	T	U
chlorinated solvents	T	U	T	T	T	T
coolants	A	A	T	A	T	T
cyclohexane	T	T	U	A	U	T

A = Acceptable Resistance M = Moderate Resistance U = Unacceptable Resistance T = Not Tested	NEMA 4X Bezel	NEMA 4X Gasket	O-Ring Gasket	Keypad	Plastic Housing	Touch Screen
detergents	A	A	A	A	M	A
ethanol	A	T	A	A	U	A
ethyl acetate	A	T	M	A	U	T
fruit juices	A	A	T	A	A	A
greases	A	A	T	A	M	A
glycol antifreeze	A	A	A	A	T	T
hexane	A	T	U	T	A	T
methyl chloride	M	T	U	T	U	T
methyl ethyl ketone	A	T	A	A	U	T
methylene chloride	A	T	U	T	T	T
oil, animal	A	A	A	A	M	A
oil, cutting	A	A	T	A	U	A
oil, diesel	A	A	U	A	T	A
oil, hydraulic	A	A	T	A	T	A
oil, lube	A	A	T	A	M	A
oil, motor	A	A	T	A	M	A
oil, petroleum	A	A	T	A	M	A
oil, silicone	A	A	T	A	M	A
oil, vegetable	A	A	U	A	M	A
salt spray, 5%	A	A	A	A	A	A
soap solution	A	A	A	A	M	A
water	A	A	A	A	A	A
xylene	A	T	U	A	U	T

A-1

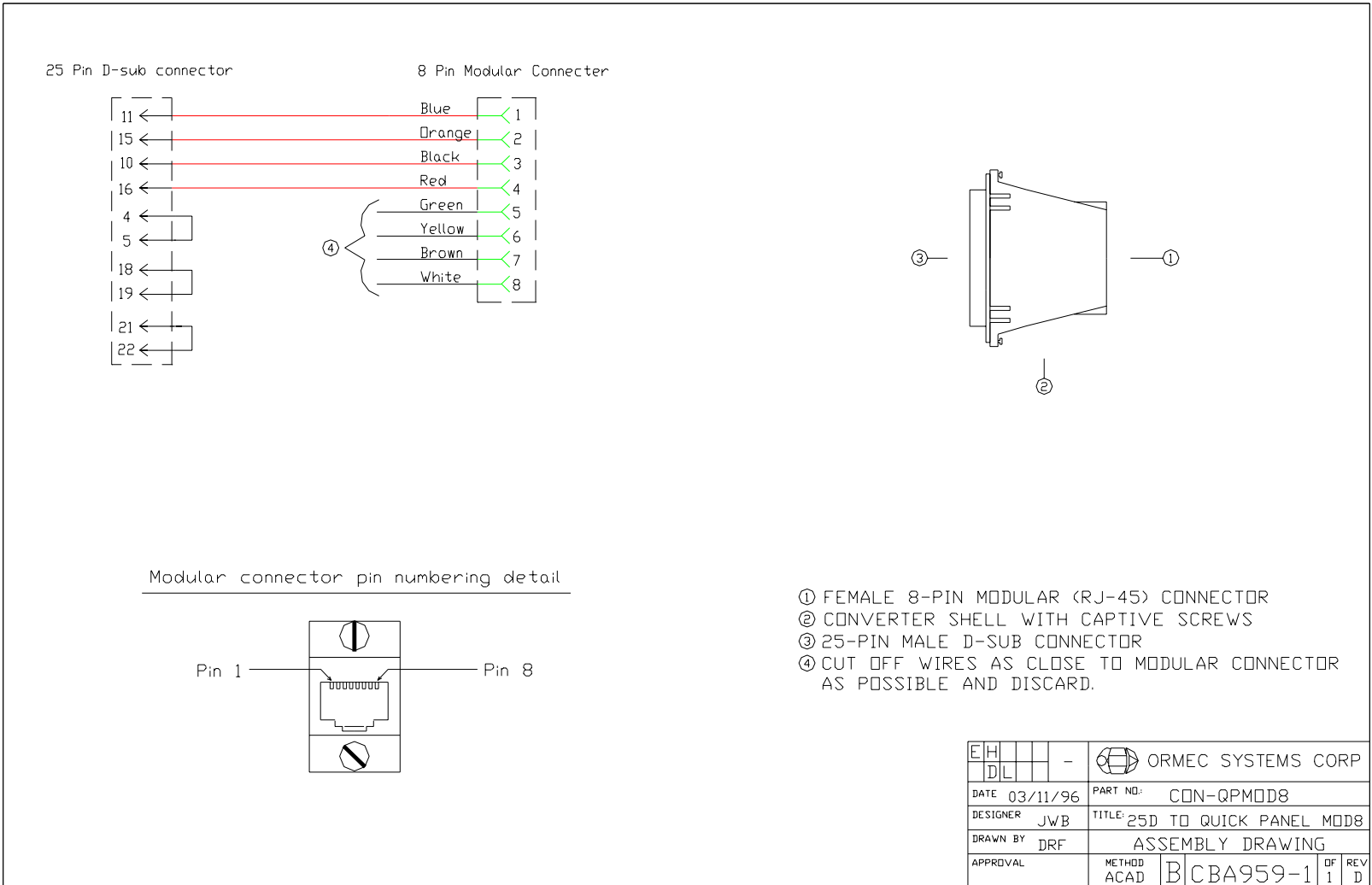

MMI-QP2b

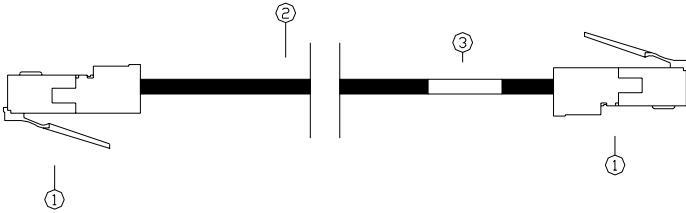
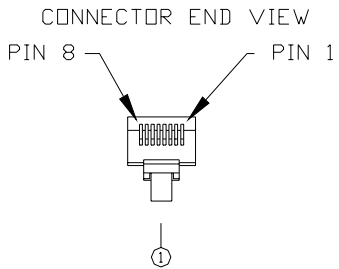
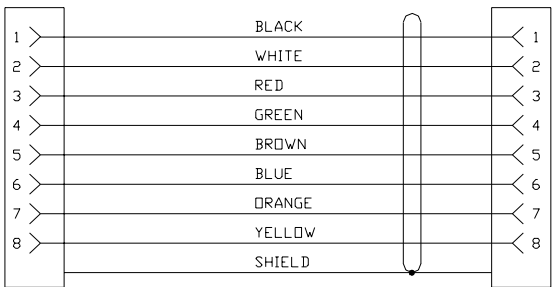

- ① 8 PIN, MALE, SHIELDED, MODULAR CONNECTOR : AMP PART # 5-555178-4
TERMINATING TOOL FOR ABOVE: AMP PART # 231652-1
SEE AMP APPLICATION SPECIFICATION # 114-06016 FOR INSTRUCTIONS
 - ② 8 CONDUCTOR, SHIELDED, FLAT OVAL CABLE
 - ③ LABEL, THE LAST TWO DIGITS OF THE PART NUMBER
SPECIFY THE LENGTH OF THE CABLE IN FEET
- PRINT CABLE LABEL AS SHOWN
WHERE NNN = CABLE LENGTH (MAXIMUM CABLE LENGTH IS 500 Ft.)



EH				-	ORMEC SYSTEMS CORP
DL					PART NO: CBL-M0D8/NNN
DATE	10.12.92	TITLE MotionDATA CBL,CPU/CPU			
DESIGNER	KRF	DRAWN BY EJB			
DRAWN BY		EJB		ASSEMBLY DRAWING	
APPROVAL	METHOD	B	CBA162-1	OF 1	REV B

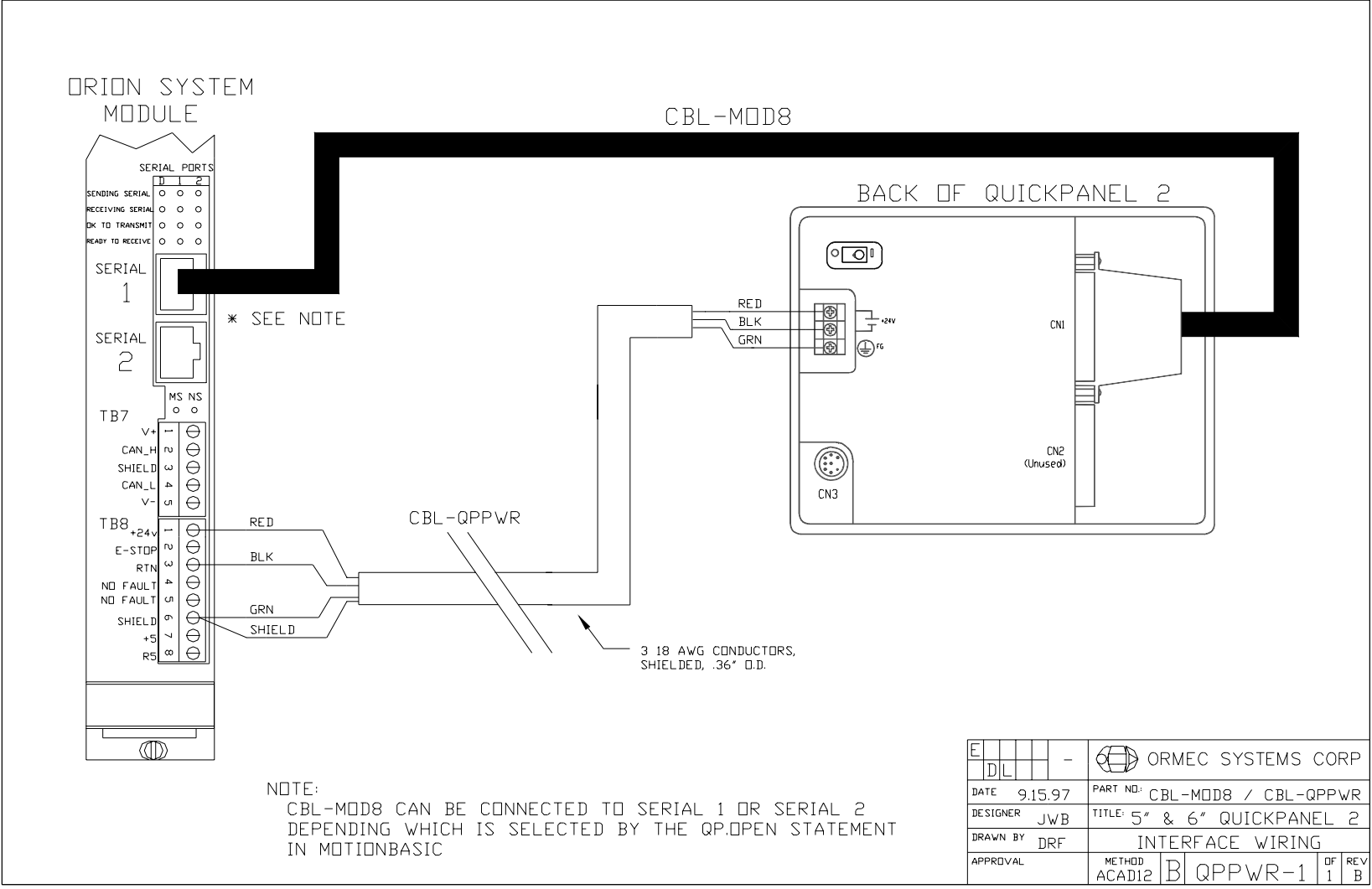

E				-	ORMEC SYSTEMS CORP
DL					
DATE	9.15.97	PART NO.:	CBL-MOD8 / CBL-QPPWR		
DESIGNER	JWB	TITLE:	5" & 6" QUICKPANEL 2		
DRAWN BY	DRF	INTERFACE WIRING			
APPROVAL	METHOD	B	QPPWR-1	DF	REV
	ACAD12			1	B

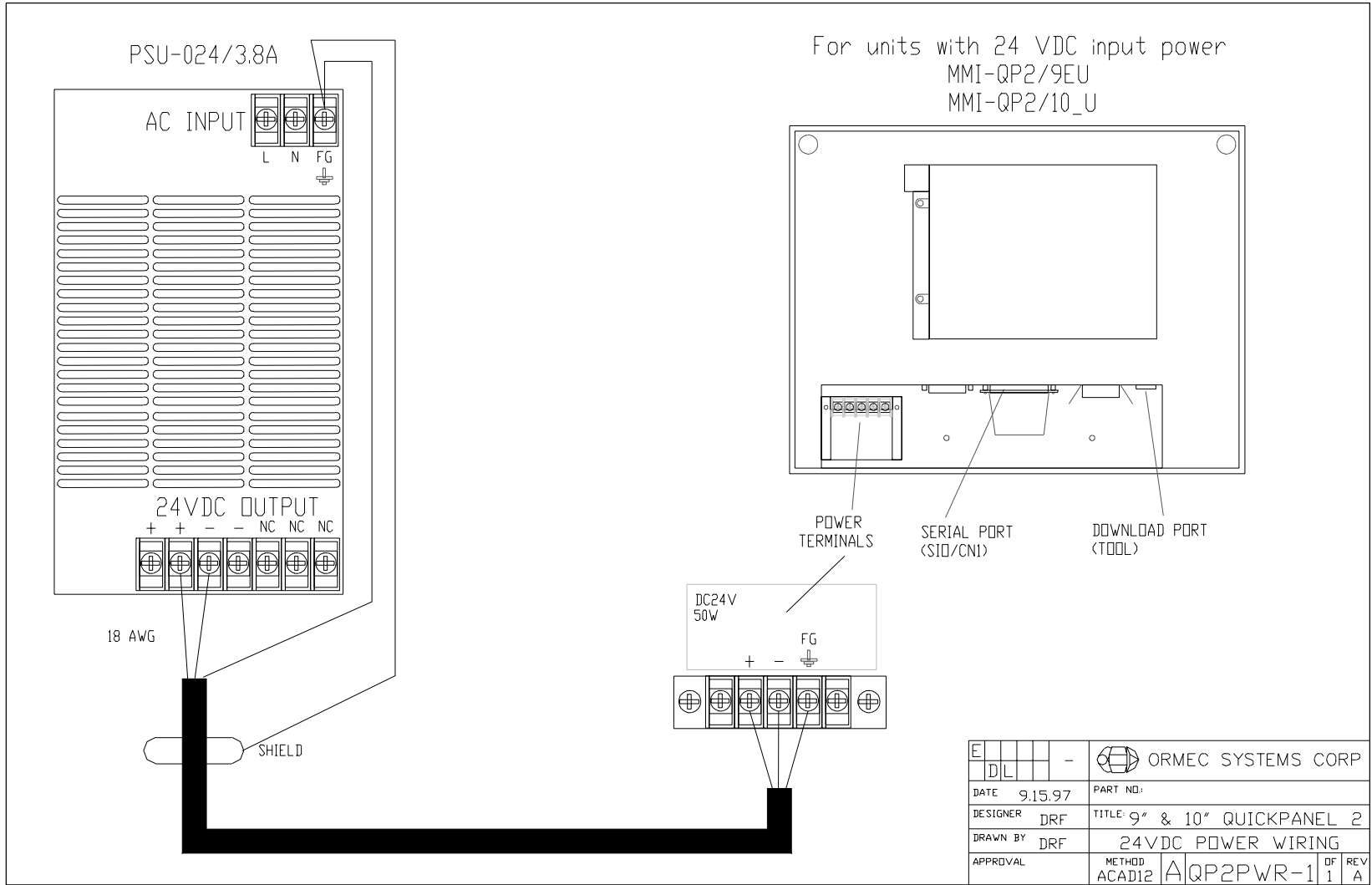

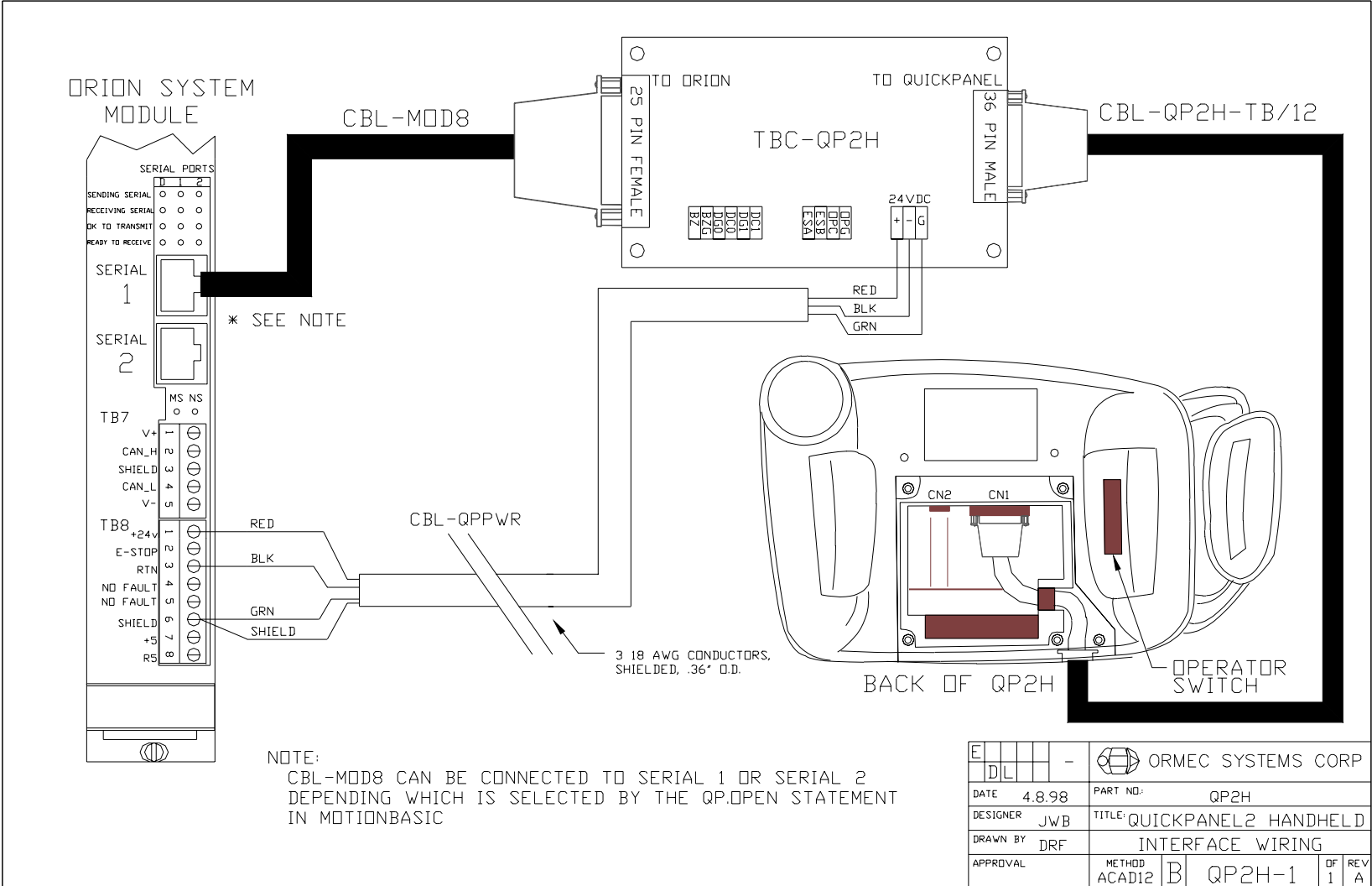

E			ORMEC SYSTEMS CORP		
DL	-		PART NO: QP2H		
DATE	4.8.98		DESIGNER JWB TITLE: QUICKPANEL 2 HANDHELD		
DRAWN BY	DRF		INTERFACE WIRING		
APPROVAL	METHOD	B	QP2H-1	DF	REV
	ACAD12			1	A