



ORMEC

HMI Touchscreens

Flatpanel Touchscreens



ORMEC's MMI-320 and MMI-640 flatpanel touchscreens provide a variety of sizes and functionality for human-machine interfaces. MMI-320/640 units are available in six, eight and ten inch screen sizes (diagonal), with TFT color displays.

The MMI-320/640 touchscreen is designed to provide the operator an effective way to control machine operation. The operator can easily be alerted to machine alarms and status conditions. Different panels can be quickly selected to present different sets of machine functions typically found for setup, maintenance, changing product runs and fault conditions. Operator control functionality can be built into the MMI-320/640 representing a typical factory operator panel, without the bulky hardware, I/O modules and wiring needed to build it.

Each individual panel can be designed and built in minutes using the "drag and drop" graphical objects found in the EasyBuilder application development utility. EasyBuilder includes a library of standard shapes to select from, as well as the ability to use bitmap images, when creating various panel objects. When upgrading a machine, the "look and feel" of an existing physical panel can be maintained to reduce operator retraining. After the design and installation of an MMI-320/640 is complete, its flexibility allows the designer to easily add and change control functions without having to physically add switches, legend plates, I/O modules and their associated wiring.

MMI-320/640 touchscreens include built-in recipe management, allowing for easy storage and retrieval of machine setup parameters. Having this powerful capability in the HMI eliminates the need for developing recipe management in the machine control application program, saving



ORMEC's touchscreen operator interfaces provide a fully graphical, easy to use human-machine interface.

software development time and simplifying the system design.

Each MMI-320/640 unit is shipped with the latest revision of the EasyBuilder development software and

a development communications serial cable. This insures that the customer has the software and cabling necessary to properly install and configure their HMI.

Ordering Guide

Operator Interface Terminals

MMI-320/3TE	5.7" diagonal, 320w x 234h pixels, TFT Color, Ethernet
MMI-640/8T	7.7" diagonal, 640w x 480h pixels, TFT Color, Ethernet
MMI-640/10T	10.4" diagonal, 640w x 480h pixels, TFT Color, Ethernet

Each Operator Interface unit includes EasyBuilder development software and serial cable.

Ethernet Cables and Accessories

CBL-SMLC-MMI-232/15	Serial Cable, SMLC to MMI-320/640, RS-232, 15 ft. (\$1.10/ft. for other lengths)
CBL-MMI-MMI/15	Serial Cable, MMI-320/640 to MMI-320/640 (multi-drop), 15 ft. (\$1.10/ft. for other lengths)
CBL-PC-MMI	Serial Cable, PC to MMI-320/640, for application program download
EISK5-100T	Ethernet Switch, 100BASE-T, 5 port, 24 VDC input, DIN rail mount
CBL-ENET/x	Cable, Ethernet, RJ45, 3, 7, 10, 25, 50, 75 & 100 ft.
CBL-ENETX/x	Cable, Ethernet crossover, RJ45, 3, 7, 10 & 25 ft.

Development Software

EBD-SDK/C	EasyBuilder, MMI-320/640 application development software
-----------	-----------------------------------------------------------

cludes
serial

Operation

Communications with an SMLC controller can be through either a serial connection using Modbus RTU, or Ethernet using Modbus/TCP. Screen objects are tagged to input and output registers that are mapped to input and output variables in the CoDeSys application program running on the SMLC. Touching a screen object, or entering data, sets the state of the variables in the SMLC application program. How the change of state is used in the program defines the object's control function.

Graphical Panel Objects

- Pilot Light (Bit Lamp)
- Word Lamp
- Force Coil (Set Bit)
- Write Register (Set Word)
- Toggle Switch
- Multi-State Switch
- Function Key
- Numeric Input
- Numeric Display
- ASCII Data
- ASCII Display
- Moving Shape
- Animation
- Indirect Window
- Direct Window
- Alarm Display
- Trend Display
- XY Plot
- Bar Graph
- Meter Display
- Alarm Bar
- Recipe Upload/Download
- Event Display

Mounting & Sealing

HMI-320/640 units are cabinet mounted, and feature a gasket and four or six mounting brackets to maintain a NEMA 4 rating.

Cabinet Mounted Unit Dimensions

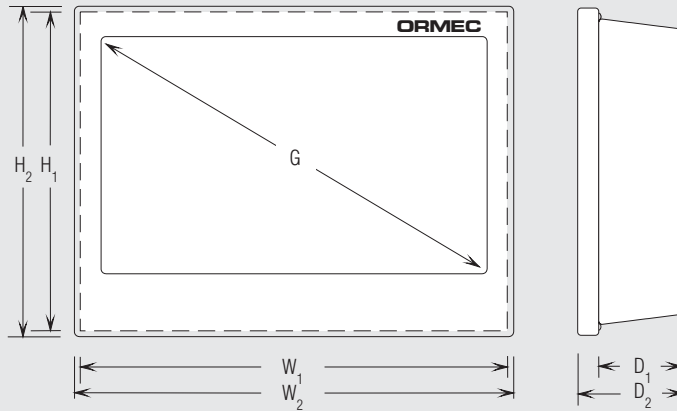

	Dimension	MMI-320/6M, 6C, 6T	MMI-640/8C	MMI-640/10C, 10T, 10M
Mounting & Cutout	G	5.7" 145 mm	7.7" 196 mm	10.4" 264 mm
	H1	5.43" 138 mm	6.57" 167 mm	8.86" 225 mm
	W1	7.56" 192 mm	8.75" 222 mm	11.89" 302 mm
	D1	2.55" 65 mm	1.17" 30 mm	2.04" 52 mm
Overall	H2	5.9" 150 mm	6.93" 176 mm	9.37" 238 mm
	W2	8.0" 203 mm	9.09" 231 mm	12.4" 315 mm
	D2	2.95" 75 mm	1.57" 55 mm	2.44" 62 mm

LED Indicators

Each HMI-320/640 unit has three status indicator LEDs to assist with installation and troubleshooting.

- PWR - Indicates the unit has power.
- CPU - Indicates that the processor is operating properly.
- COM - Flashes during serial communications.

CE Mark

All HMI-320/640 units are CE Marked, indicating compliance with European Union directives EN 55011: Group 1, Class A; EN50081-2 (Also US FCC Class A) and EN50082-2.

General Specifications

Touch panel type	Resistive
Color Type	
TFT	TFT 256 color
Touch Resolution	
6 inch	320W x 234H pixels
8 and 10 inch	640W x 480H pixels
Installation	
All sizes	Cabinet Mount
Vibration	10 to 25Hz 2Gs on each x,y, z plane for 30 min.

Temperature	
Operating	0C to 45C
Storage	-10C to 60C
Relative Humidity	
Operating	10% to 90% non-condensing
Storage	5% to 85% non-condensing

Enclosure Ratings
NEMA 4/IP65 front panel (O-ring seals).

Weight	
MMI-640/10T	4.4 lbs (2.0 kg)
MMI-640/8T	2.6 lbs (1.2 kg)
MMI-320/3TE	1.8 lbs (0.8 kg)

Input Power
21-25 Volt DC @ 700mA

CE
Complies with EN50081-2 and EN50082-2 standards

EMI
Complies with FCC Class A