



HMI Touch Screens

MMI-8000 Series

ORMEC's MMI-8000 flat panel touch screens provide a variety of sizes and functionality for human-machine interfaces. They are color TFT LCD displays.

The touch screens are designed to provide the operator an effective way to control machine operation. The operator can easily be alerted to machine alarms and status conditions. Different displays can be quickly selected to present different sets of machine functions typically found for setup, maintenance, changing product runs and fault conditions.

Operator control can be built into the MMI-8000 representing a conventional factory operator panel, without additional bulky hardware, I/O modules and wiring.

Each individual panel can be designed and built in minutes using the "drag and drop" graphical objects found in the EasyBuilder 8000 application development utility.

The EasyBuilder Software includes built-in recipe management, allowing for easy storage and retrieval of machine setup parameters. Having this powerful capability in the HMI eliminates the need for developing recipe management in the machine control application program, saving software development time and simplifying the system design. Each MMI-8000 unit is shipped with the latest revision of the EasyBuilder 8000 development software. The latest version of the EasyBuilder 8000 software is always available to be downloaded from the ORMEC web site, www.ormec.com.



ORMEC's touch screen operator interfaces provide a fully graphical, easy to use human-machine interface.

Operation

Communications with an ORMEC controller can be through either a serial connection using Modbus RTU, or Ethernet using Modbus/TCP.

Screen objects are tagged to input and output registers that are mapped to input and output variables in the application program running on the controller.

Touching a screen object, or entering data, sets the state of the variables in the application program. How the change of state is used in the program defines the object's control function.

Ordering Guide

Operator Interface Terminals

MMI-8050*	4.3" diagonal, 480w x 272h pixels, TFT Color, Ethernet
MMI-8070*	7.0" diagonal, 800w x 480h pixels, TFT Color, Ethernet
MMI-8100*	10.4" diagonal, 800w x 480h pixels, TFT Color, Ethernet
MMI-8121	12.1" diagonal, 800w x 600h pixels, TFT Color, Ethernet
MMI-8150	15.0" diagonal, 1024w x 768h pixels, TFT Color, Ethernet

Each Operator Interface unit includes EasyBuilder 8000 development software and Ethernet crossover cable.

** 16 x 9 wide screen format.*

Ethernet Cables and Accessories

CBL-SMLC-MMI8/x	Serial Cable, SMLC to MMI-8000, RS-232, x ft.
EISK5-100T	Ethernet Switch, 100BASE-T, 5 port, 24 VDC input, DIN rail mount
CBL-ENET/x	Cable, Ethernet, RJ45, 3,7,10,25,50,75, & 100 ft
CBL-ENETX/x	Cable, Ethernet, crossover, RJ45, 3,7,10 & 25 ft

Development Software

Easy Builder 8000 included.

Graphical Panel Objects

- Pilot Light (Bit Lamp)
- Word Lamp
- Force Coil (Set Bit)
- Write Register (Set Word)
- Toggle Switch
- Multi-State Switch
- Function Key
- Numeric Input
- Numeric Display
- ASCII Data
- ASCII Display
- Moving Shape
- Animation
- Indirect Window
- Direct Window
- Alarm Display
- Trend Display
- XY Plot
- Bar Graph
- Meter Display
- Alarm Bar
- Recipe Upload/Download
- Event Display

LED Indicators

Each MMI-8000 unit has three status indicator LEDs to assist with installation and troubleshooting.

PWR - Indicates the unit has power.

CPU - Indicates that the processor is operating properly.

COM - Flashes during Ethernet communications.

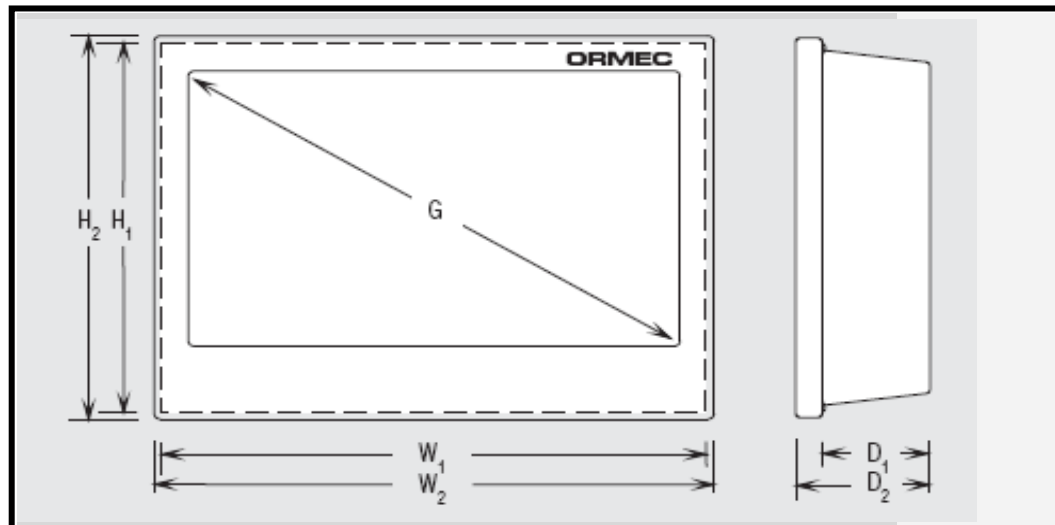

	Dimension	8050	8070	8100	8121	8150
Mounting & Cutout	G	4.3"	7.0"	10.4"	12.1"	15"
		109 mm	178 mm	264 mm	307 mm	381 mm
	H1	3.66"	5.43"	7.91"	9.09"	10.98"
		93 mm	138 mm	201 mm	231 mm	279 mm
Overall	W1	4.69"	7.56"	10.2"	12.01"	13.86"
		119 mm	192 mm	259 mm	305 mm	352 mm
	D1	1.27"	1.4"	1.68"	1.81"	2.13"
		32 mm	36 mm	43 mm	46 mm	54 mm
	H2	4.02"	5.76"	8.38"	9.57"	11.54"
		102 mm	146 mm	213 mm	243 mm	293 mm
	W2	5.04"	7.89"	10.67"	12.68"	14.41"
		128 mm	200 mm	271 mm	322 mm	366 mm
	D2	1.51"	1.68"	1.96"	2.01"	2.32"
		38.25 mm	43 mm	50 mm	51 mm	59 mm

Mounting & Sealing

MMI-8000 units are cabinet mounted, and feature a gasket and four or six mounting brackets to maintain a NEMA 4 rating.

CE Mark

All MMI-8000 units are CE Marked, indicating compliance with European Union directives EN 55011: Group 1, Class A; EN50081-2 (Also US FCC Class A) and EN50082-2

General Specifications

Touch panel type	Resistive	Temperature		Weight	
Color Type	TFT 65536 color	<i>Operating</i>	0C to 45C	<i>MMI-8150</i>	6.5 lbs (2.9 kg)
Display Resolution		<i>Storage</i>	-10C to 60C	<i>MMI-8121</i>	4.6 lbs (2.1 kg)
<i>MMI-8050</i>	480w x 272h pixels	Relative Humidity		<i>MMI-8100</i>	3.3 lbs (1.5 kg)
<i>MMI-8070/8100</i>	800w x 480h pixels	<i>Operating</i>	10% to 90% non-condensing	<i>MMI-8070</i>	1.9 lbs (0.85 kg)
<i>MMI-8121</i>	800w x 600h pixels	<i>Storage</i>	5% to 85% non-condensing	<i>MMI-8050</i>	.66 lbs (0.3 kg)
<i>MMI-8150</i>	1024w x 768h pixels	Enclosure Ratings		Input Power	24 Volt DC +/- 5%
Installation		<i>NEMA 4/IP65 front panel (O-ring seals).</i>		<i>MMI-8150</i>	1.6 A
<i>All sizes</i>	Cabinet mount	EMI		<i>MMI-8121</i>	800 mA
Vibration	10 to 25Hz 2Gs on each x,y,z plane for 30 min.	<i>Complies with FCC Class A</i>		<i>MMI-8100</i>	300 mA
		CE		<i>MMI-8070</i>	250 mA
		<i>Complies with EN50081-2 and EN50082-2</i>		<i>MMI-8050</i>	250 mA